OPERATION MANUAL

SI unit

EX120-SDN1-X26

EX121-SDN1-X26



EX122-SDN1-X26

EX124D/U-SDN1-X26

1.Safety instructions	-----	P3
2.Specifications		
2-1.General specifications	-----	P4
2-2.Electrical and network specifications	-----	P4
2-3.Applicable solenoid valve series	-----	P5
3.Wiring and setting		
3-1.Connection type	-----	P5
3-2.Address setting	-----	P8
4.LED indicator and Physical dimensions		
4-1.LED indication	-----	P10
4-2.Physical dimensions	-----	P10
5.EDS(Electronic Data Sheet)File	-----	P13
6.Trouble Shooting	-----	P14

These safety instructions are intended to prevent a hazardous situation and/or equipment damage. These instructions indicate the level of potential hazard by label of "CAUTION" , "WARNING".

To ensure safety, be sure to observe ISO, JIS and other safety practices.

-  **CAUTION:** Operator error could result in injury or equipment damage.
-  **WARNING:** Operator error could result in serious injury or loss of life.

CAUTION

Thoroughly read this manual and operate the product within the specified range. Follow the instructions.

Do not drop or impart any impact to the product.

Use within specified voltage range. Use outside of specified voltage will cause malfunction, damage of unit, electric shock, and fire.

Do not touch the terminal or internal circuit board while they are energized. It may cause malfunction, damage to unit, and electric shock.

Use within operating ambient temperature. Do not use where temperature can rapidly change even though it is within the specifications.

Foreign objects should be prevented from entering the product. Contamination by foreign objects, such as wire chips will cause fire, breakage, and malfunction.

Use within the operating environment of the protection structure. In case of IP20, avoid use in the place where water and oil scatter. To realize IP65, install manifold properly and give some prevention against splash of liquid to electrical entry.

Carry out periodical checks to confirm correct operation. Safety may not be maintained by unintentional malfunction or incorrect operation. Design must consider the space necessary for maintenance.

As the contents of this manual is sometimes changed without the previous announcement, understand them beforehand, please.

SI unit is not explosion proof. Operation in explosive environment may cause explosion accident.

WARNING

The product specified here is designed to be used in standard factory automation equipment. Do not use in machinery and/or equipment where operators may be injured, and malfunction or failure may cause loss of life.

Do not disassemble to repair or modify the product.

Connection

CAUTION

Power of the product and all other equipments should be turned off while wiring.

Tighten the wiring with connector and terminal screw completely. Short circuit, fire, and malfunction will be caused if connector and terminal screw are not tightened enough.

Avoid incorrect wiring. It may damage the product and/or other equipments.

Ensure that the FG terminal is correctly grounded.

Power with correct capacity should be prepared by considering the in-rush current when starting.

Influence of noise should be avoided for the wiring. Wiring should be separated from power cables and high voltage cables.

Ensure that the power is within the specified voltage range.

Ensure that the cable is capable of supporting the solenoid valve and SI unit in terms of rating.

Applicable solenoid valves

CAUTION

SMC offers no guarantee against malfunction and damage of unit when valves not described to "2-3.Applicable solenoid valve series" and loads which is not valve are connected.

2. Specifications

2-1. General specifications

Item	Specifications				
Model	EX120 -SDN1 -X26	EX121 -SDN1 -X26	EX122 -SDN1 -X26	EX124D -SDN1 -X26	EX124U -SDN1 -X26
Operating ambient temp.	0~+55°C (with 8 points of valve ON) 0~+50°C (with 16 points of valve ON)				
Operating ambient humidity	35~85% RH (No dew condensation)				
Storage ambient temp.	-20~+60°C				
Vibration proof	50m/s ² (comply with JIS C 0911)				
Impact proof	100m/s ² (comply with JIS C 0912)				
Noise immunity	Normal mode ±1500 V Pulse 1 μs Common mode ±1500 V Pulse 1 μs Radiation ±1000 V Pulse 1 μs				
Withstand voltage	AC1000V for 1 min. between FG and external Terminal package.				
Insulation resistance	DC500V, 10MΩ between FG and external terminal Package.				
Operating environment	No corrosive gas and no dust				
Weight	110g or less	140g or less	130g or less	240g or less	
Protection	IP20			IP65	

2-2. Electrical and network specifications

Item	Specifications	
Applicable system	DeviceNet Release 2.0	
Power supply voltage for communication	DC11V~DC25V (supplied by communication connector)	
Power supply voltage for solenoid valve	DC24V +10% - 5%	
Consumption current	Communication and Internal power supply	90mA or less (DC24V)
	Power supply for Solenoid valve	1.5A or less(DC24V)
Solenoid valve Connection spec.	Output style	NPN output (Open collector)
	Connected load	DC24V, Solenoid valve with lamp-surge voltage protection circuit of 2.1W or less. (made by SMC)
	Insulation style	Opt-coupler insulation type
Residual voltage	0.4V DC or less	
Network connection spec.	Applicable DeviceNet	Volume I - Release 1.2 Volume II - Release 1.1
	MAC ID setting range	0~63 (Set by Dip switch)
	Baud Rate (Transmission speed)	500kbps, 250kbps, 125kbps (Set by Dip switch)
	Slave (branch station) type	Group 2 only server
	Connection type	T branch type, Multi drop type
	Device type	27
	Product code	1202
	Revision	Referred to EDS file.
	Vendor ID	7
	Corresponding message	Polled command (I/O message), Explicit message

SI unit I/O data (Receiving and sending data of polled command)

Item		Output(Poll request)	Input(Poll response)
Occupied byte		2 byte (Solenoid valve output)	0 byte
Sending/ receiving data	Address +0	Output No. 0 to 7	
	Address +1	Output No. 8 to 15	

*) Mapping method of sending / receiving data is different by PLC.

For further information, refer to the manual for PLC master (scanner)

Bit of each output data and corresponding solenoid valve no.								
Offset	MSB							LSB
0	No.7	No.6	No.5	No.4	No.3	No.2	No.1	No.0
1	No.15	No.14	No.13	No.12	No.11	No.10	No.9	No.8

2-3. Applicable solenoid valve series

SI unit	Valve series
EX120	VQ1000, VQ2000
EX121	VQ1000, VQ2000, SX3000, SX5000
EX122	SY3000, SY5000
EX124U/D	VQ2000, VQ4000, VQ5000

3. Wiring and Setting

3-1. Connection type

DeviceNet can be connected by T branch, Multi branch, Branch line branch and Multi drop. Total extension length of trunk and Branch line is different for different Baud rate and thickness of communication cable.

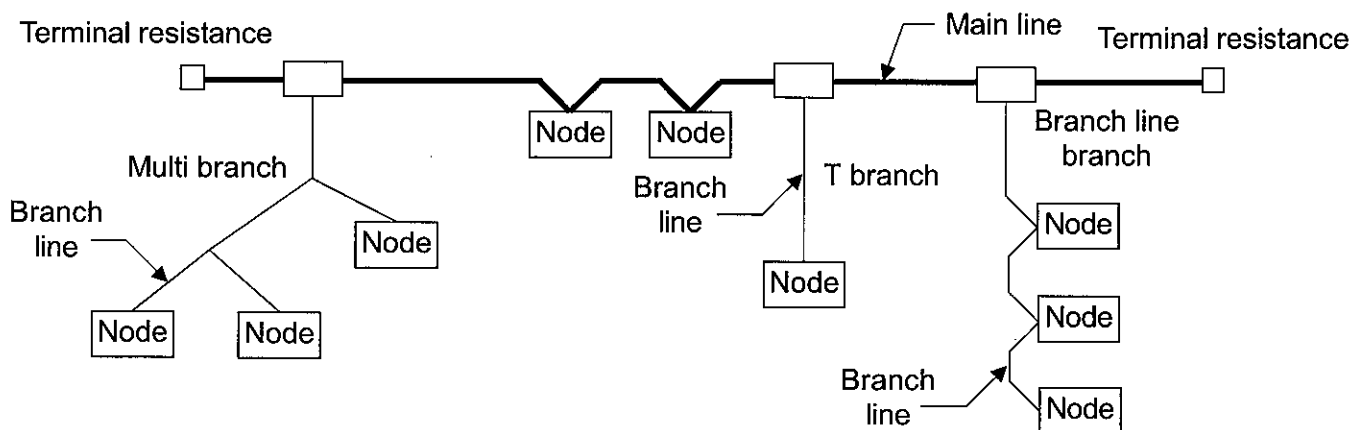

Length of cable

Communication distance	Baud rate	Total length of trunk	Length of branch line	Total length of branch line
Thick cable	500 kbps	100m or less	6m or less	39m or less
	250 kbps	250m or less		78m or less
	125 kbps	500m or less		156m or less
Thin cable	Common	100m or less		
Terminal resistance	121 ohm (1/2W)			

Cable specification

Item	Thick cable		Thin cable	
	Communication Signal	Power supply	Communication Signal	Power supply
Conductor cross section	0.82 mm ²	1.65 mm ²	0.20 mm ²	0.33 mm ²
Colors	Blue, White	Red, Black	Blue, White	Red, Black
Impedance	120 Ω ± 10%(1MHz)	---	120 Ω ± 10%(1MHz)	---
Propagation delay	1.36ns / ft(max)	---	1.36ns / ft(max)	---
Attenuation rate	500k: 0.25dB / ft 125k: 0.13dB / ft 1.00M: 0.40dB / ft	---	500k: 0.50dB / ft 125k: 0.29dB / ft 1.00M: 0.70dB / ft	---
Conductor resistance	6.9 Ω / 1000ft(max)	3.6 Ω / 1000ft (max)	28 Ω / 1000ft(max)	17.5 Ω / 1000ft(max)

⚠ CAUTION

For Multi drop connection, prepare plug connector for T branch separately.

(Example: TMSTBP 2.5...- STF -5.08 made by Phoenix Contact Corp.)

Use DeviceNet special cable for communication cable.

Be sure to connect DeviceNet special terminal resistor with both ends of trunk.

○ Wiring of cable for solenoid valve power supply and communication

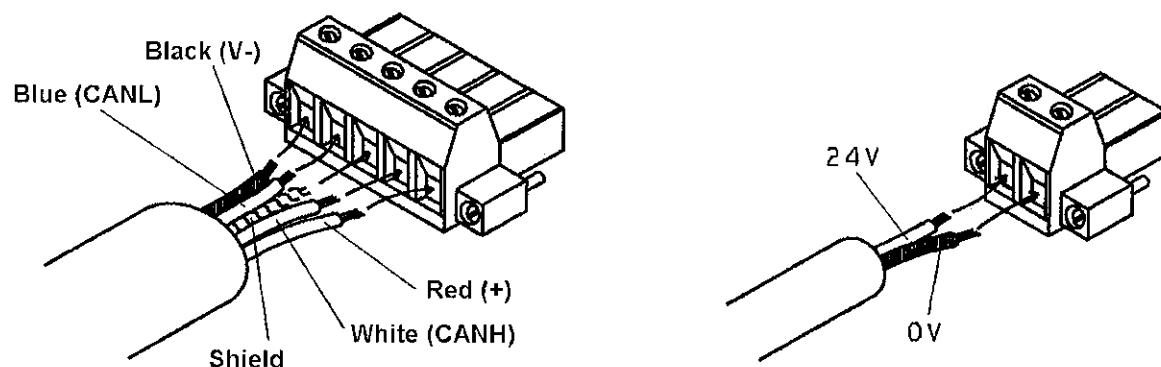

Communication connector for DeviceNet

Terminal	Wire color	Connected to
V-	Black	(-) side of power supply cable
CANL	Blue	Low side of communication cable
FG	-	Ground / Shield
CANH	White	High side of communication cable
V+	Red	(+) side of power supply cable

Power supply connector for solenoid valve

Terminal	Wire color	Connected to
24V	-	(+) side of solenoid valve source supply source
0V	-	(-) side of solenoid valve source supply source

⚠ CAUTION

- Before wiring, be sure to turn power supply off.
- Screw for connectors is M3. Tighten them properly by torque of 0.5~0.6 [N·m].
- SI unit isn't available for monitoring of power supply for solenoid valve.
- Do not put cable specified by DeviceNet with/near high voltage line or strong electric line such as driving line.

3-2. Address setting

Before setting of address by DIP switch, turn power supply for communication cable in SI unit "OFF".

Setting (binary) of following items is available by DIP switch installed to cover.

- 1) Node address (00~63)
- 2) Communication speed (125kbps, 250kbps, 500kbps)

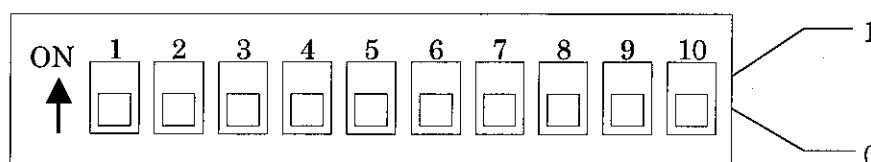

<Setting of node address>

Node address	SW1	SW2	SW3	SW4	SW5	SW6
	1	2	4	8	16	32
#0	0	0	0	0	0	0
#1	1	0	0	0	0	0
#2	0	1	0	0	0	0
⋮						
#62	0	1	1	1	1	1
#63	1	1	1	1	1	1

<Setting of mode>

0	HW mode Setting of address and speed is done by SW.1~8.
1	SW mode Setting of address and speed is done via network. ※SW.1~8 isn't available.

<Setting of communication speed>

Setting		Communication speed (kbps)	Max. transmission distance (m)			
SW7	SW8		Length of trunk		Length of branch line	Total length of branch line
			Thick cable	Thin cable		
0	0	125	500	100	6	156
1	0	250	250			78
0	1	500	125			39
1	1	Not used	Not used			

<Setting of output when communication stops>

SW.9	Output condition of solenoid valve when communication stops (Time-out error of I/O connection) or Fault message is received. (Initial condition of solenoid valve)
1	All outputs are held. (Fault action = 1, Fault value = 0)
0	All outputs are cleared. (Fault state = 0, Fault value = 0)

⚠ CAUTION

- When shipped, node address of 63 and communication speed of 125kbps are set in advance (in both HW and SW mode).
- Address and communication speed set in SW mode are held even if the power supply of SI unit turns off. If re-application of power supply is done in HW mode, values are erased and address and communication speed set by switch are memorized.

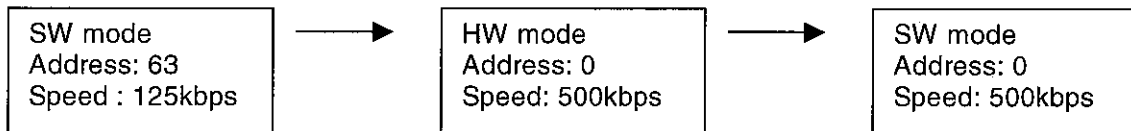

- When shipped and with communication stopped, output is set to 0 (cleared). And it is possible to change output setting with communication stopped by one point individually via network of DeviceNet. In this case, setting of SW. 9 become unavailable.

4.LED indicator and Physical dimensions

4-1 LED indication

EX120-SDN1-X26
EX121-SDN1-X26
EX122-SDN1-X26

EX124D-SDN1-X26
EX124U-SDN1X26

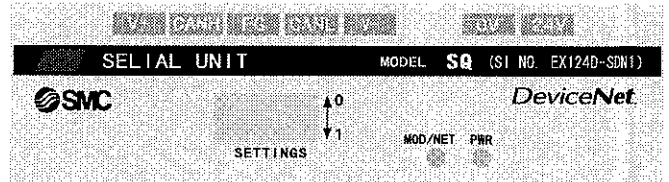
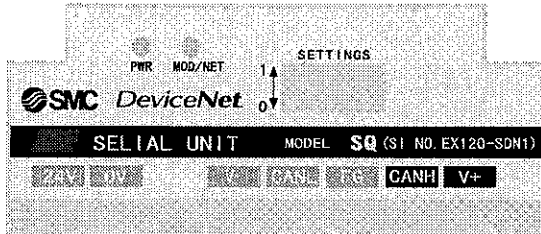

Indication	Contents	
PWR	Green Lights up when power for DeviceNet line is supplied.	
MOD / NET	Lights off	SI unit isn't on line or power supply for communication line isn't turned on.
	Green flashing	Waiting for connection (ON line)
	Green lights up	Connection completed (ON line)
	Red flashing	Connection time out (Minor communication error)
	Red lights up	MAC ID duplication error or BUS OFF error (Major communication error)

4-2 Physical dimensions

SI unit (EX120-SDN1-X26)

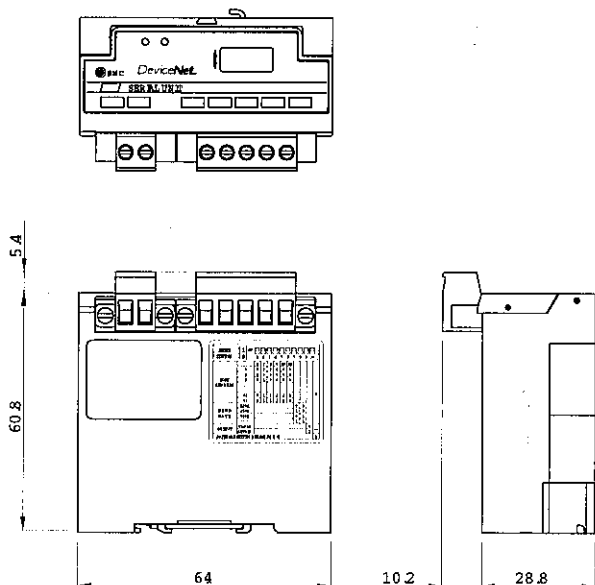

SI unit (EX121-SDN1-X26)

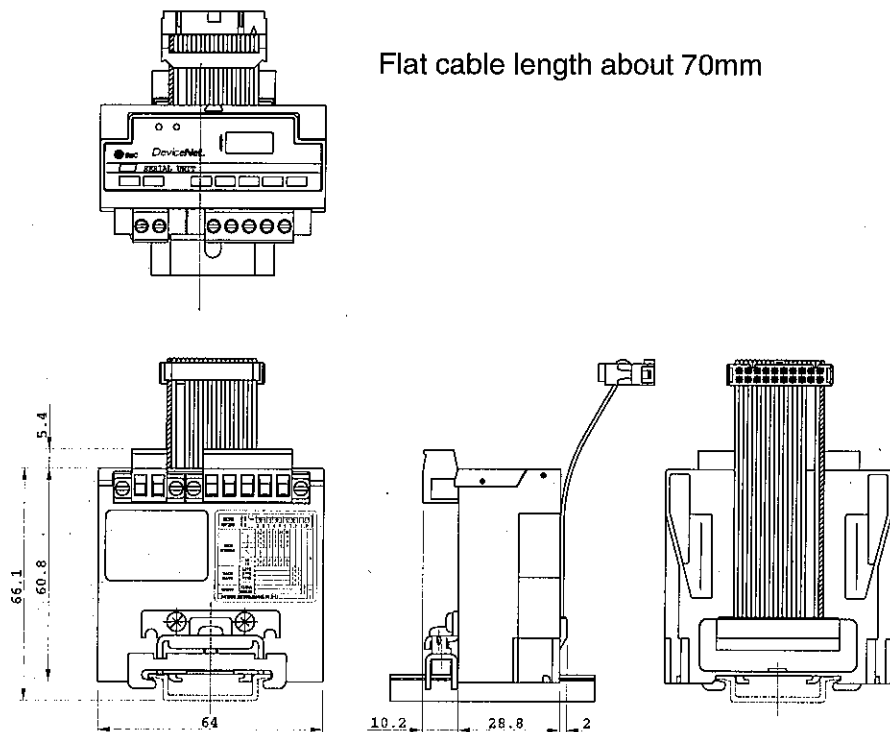

SI unit (EX122-SDN1-X26)

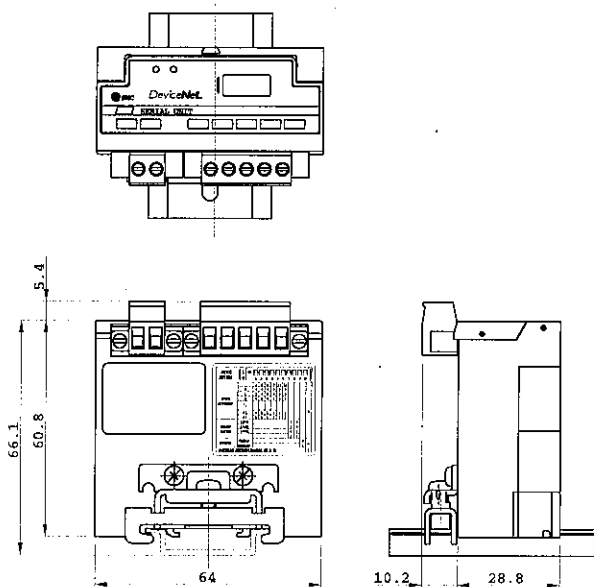

SI unit (EX124D-SDN1-X26)

SI unit (EX124U-SDN1-X26)

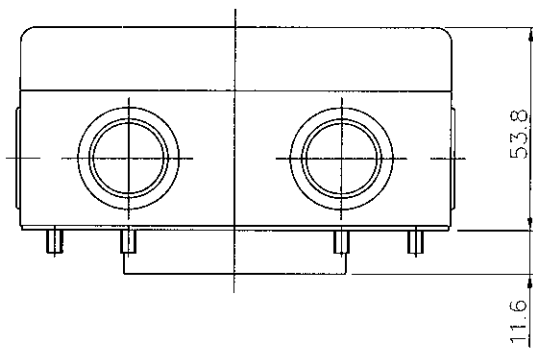
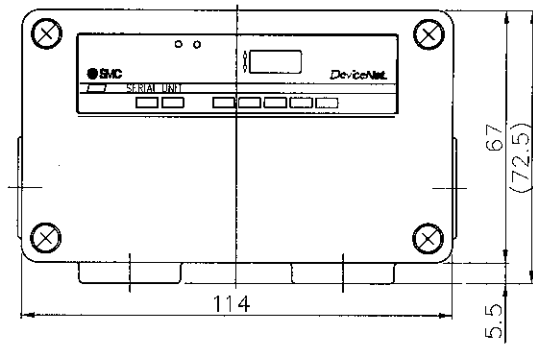
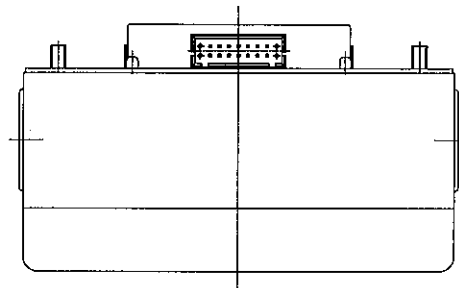
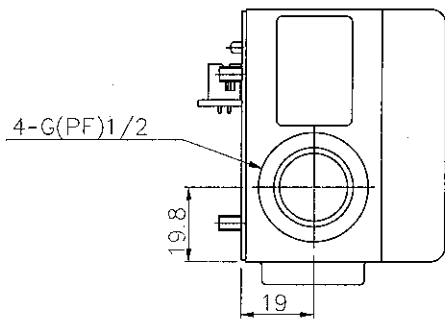

5.EDS (Electronic Data Sheet) File

SMC CORPORATION
Doc. No. EX##-OME1012

The EDS File is a file which described ID information on SI unit and important information in the operation.

The DeviceNet controller or scanner automatically recognizes the SI unit by referring to the EDS File.

*Please refer to the undermentioned list when DeviceNet controller or the scanner dose not automatically recognize the EDS File.

```
$ Electronic Data Sheet File for
$ SMC EX120-SDN1(-X26) Serial Interface Unit

[File]
  DescText = "SMC EX120-SDN1-X26 EDS File";
  CreateDate = 06-27-1998;          $ created
  CreateTime = 10:30:00;
  Revision = 1.1;                   $ Revision of EDS

[Device]
  VendCode = 7;
  VendName = "SMC Corp.";
  ProdType = 27;
  ProdTypeStr = "Pneumatic Valve";
  ProdCode = 1202;
  MajRev = 1;                       $ Device Major Revision
  MinRev = 1;                       $ Device Minor Revision
  ProdName = "Valve Manifold SIU";
  Catalog = "EX120-SDN1-X26";

[IO_Info]
  Default = 0x0001;                 $ Poll(Bit 0)
  PollInfo = 0x0001 , 0 , 1;       $ Prod. Cnxn=0
                                     $ Cons. Cnxn=1
  Output1 = 2,                      $ 2 byte
    0,                               $ All bits are significant
    0x0001,                          $ Poll Only Connection
    "Solenoid Output",               $ Name String
    6,                               $ Path Size
    "20 04 24 23 30 03",            $ Assy Obj Inst 23 Attr 3
    "",                              $ Help String
```

MOD/NET LED	Cause & Countermeasure
Lights off	<p><u>PWR LED lights off</u> <Countermeasure> Confirm that power for SI unit circuit is supplied. Confirm correct wiring. If above countermeasures do not improve status, please exchange SI unit.</p> <p><u>PWR LED lights up</u> <Countermeasure> Confirm that baud rate is set correctly. If MOD/NET LED lights off in spite of baud rate is set correctly, change SI unit.</p>
Green flashing	<p><u>Connection waiting</u> Shows communication waiting status between SI unit and master. <Countermeasure> Confirm master operate correctly. If using scan list, ensure slave is recorded to scan list correctly.</p>
Red flashing	<p><u>Communication wire disconnected error</u> <Countermeasure> Confirm communication wire is not disconnected. <Remark> Red flashing if master power source is turned off during communication.</p>
Red lights up	<p><u>Node address overlapping error</u> <Countermeasure> Confirm there is no overlapping on the node address.</p> <p><u>BUS OFF error</u> Detects communication error. <Countermeasure></p> <p><u>Case 1</u> Communication error due to noise. Confirm there is no component or high voltage cable that generate noise around communication wire. Make some distances between communication wire and noise source.</p> <p><u>Case2</u> Communication cable problem. Confirm terminal resistance (121ohm) connects to the both ends of communication wire that is main wire of communication wire.</p> <p>If red MOD/NET LED is still lights up in spite of above countermeasures, change SI unit.</p>

CAUTION

When red MOD/NET LED is lit, even if cause is solved, SI unit do not do auto-recovery. In this case, please reset the power to SI unit circuit (Communication/Internal power supply).
SI unit isn't available for monitoring of power supply for solved valve.