

Ionizer

Nozzle type



Dust removal and static electricity elimination by air blow

- Eliminates dust clinging to lamp cover.

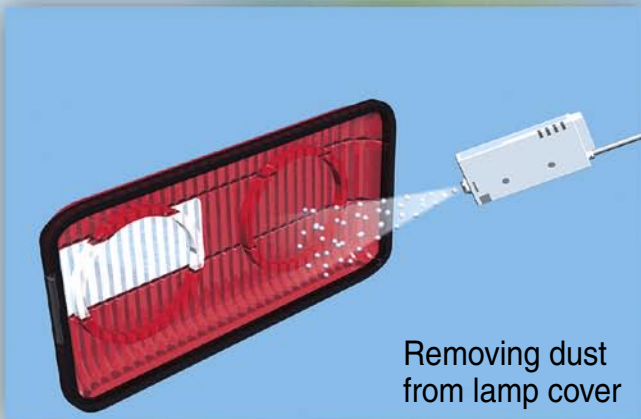

Spot type static electricity elimination

- Prevents electrostatic breakdown of electric parts.
- Prevents detachment failure.

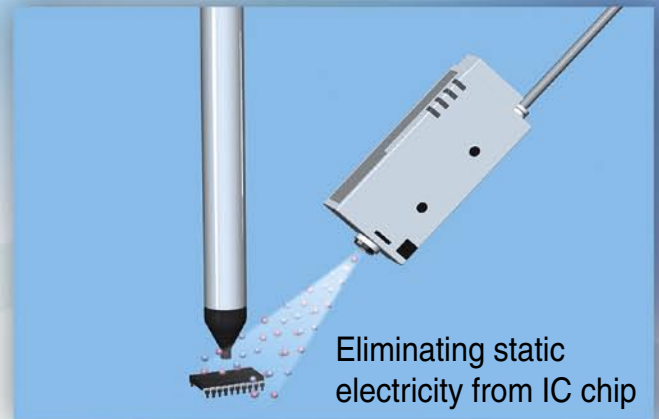

Ion balance ± 10 v (In case of energy saving static electricity elimination nozzle)

Slim design: Thickness dimension **16 mm**

RoHS compliant

① Electrode needle contamination detector

Outputs maintenance signal when detects stain or wear of an electrode needle always.

Detects optimal maintenance time, reduced labor for maintenance.

② With built-in power supply substrate

High-voltage power supply cable/ external high-voltage power supply are unnecessary.



Series IZN10

Nozzle type can be selected according to applications.

Energy saving static electricity elimination nozzle

Short range static electricity elimination, Design focuses on ion balance.

Ion balance: ± 10 V

Increases flow volume by external air intake

Static electricity elimination is possible with minimal air consumption.

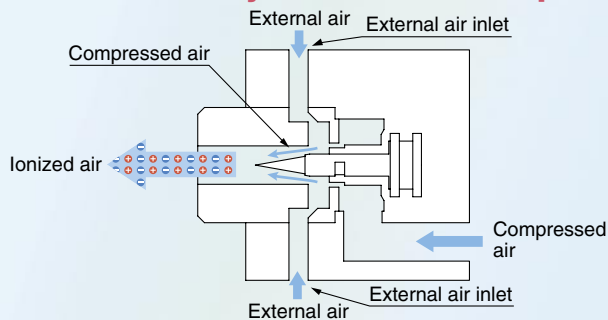

In cases with same air consumption, static electricity is eliminated in half the time.
(Supply pressure 0.3 MPa)

External air inlet	None	Yes
Air consumption flow rate ℓ/min (ANR)	10	10
Static electricity elimination time* sec	5	2.5
Ionized air flow velocity* m/s	0.4	2.5

Reduced by 50%

Improved 6 times

* At 300 mm distance

Eliminating static electricity from an electric substrate

- Prevents electrostatic breakdown of electric parts.

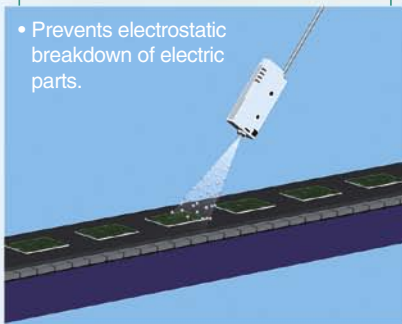

Eliminating static electricity from lens

- Removes dust from lens.
- Prevents adhesion of dust.



Eliminating static electricity from packing films

- Prevents static electricity charging when opening bags.
- Prevents static electricity cling on the inside of candy bags.

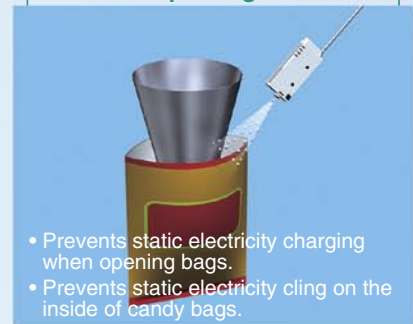

High flow static electricity elimination nozzle

Long range static electricity elimination and dust removal

Ionized air assisted by the compressed air

- Improved dust removal performance by the energy of compressed air.
- Suitable for static electricity elimination at a long distance (max. 500 mm).

Ion balance: ± 15 V

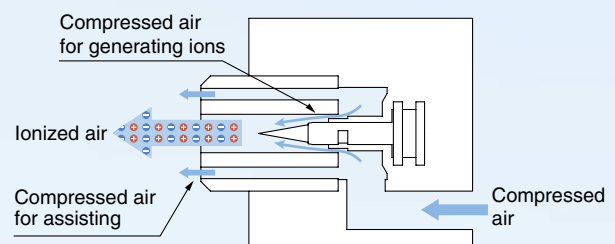

Eliminating static electricity from molded goods

- Prevents problems with the separation of molded plastic goods.

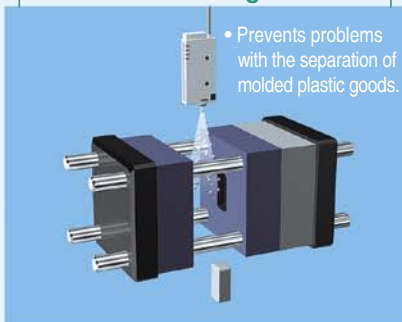

Eliminating static electricity from plastic cups

- Removes dust clinging to cup interiors.



Eliminating static electricity from parts feeder

- Prevents clogging of parts feeder.

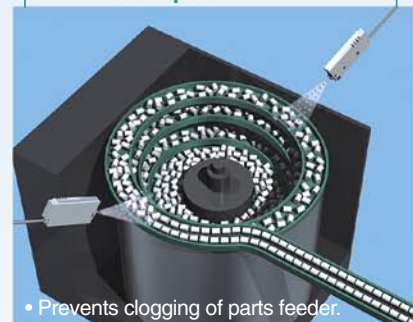

External switch input function (2 inputs)

Prevents static electricity elimination trouble due to pressure drop of compressed air.

Emission of static electricity is suspended when abnormal purge air pressure is detected by pressure switch.

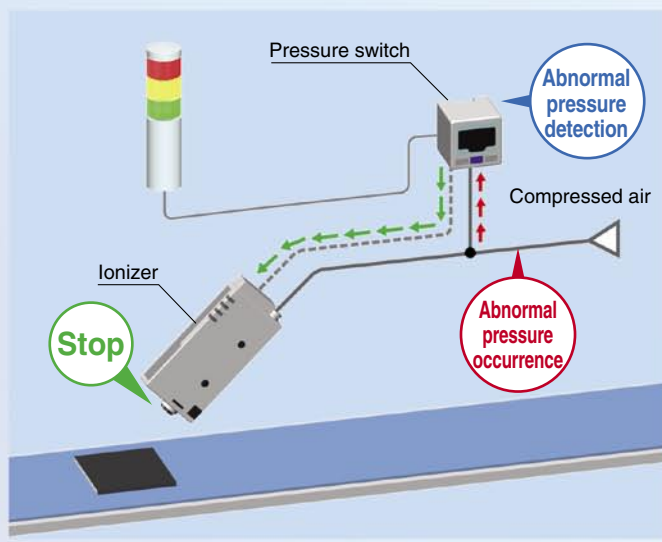

Energy saving with electrostatic sensor

Emission of static electricity is suspended when an electrostatic sensor detects that static electricity elimination is completed.

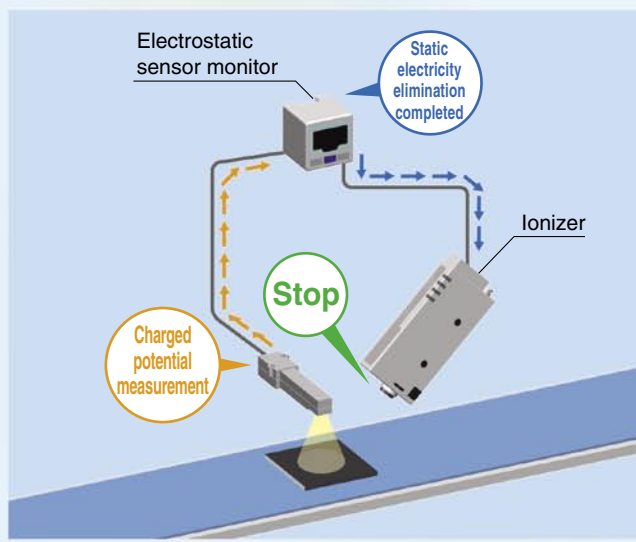

Easy maintenance

Possible to conduct maintenance on the electrode needle without removal of body. No need to readjust the nozzle angle when the ionizer is restarted.

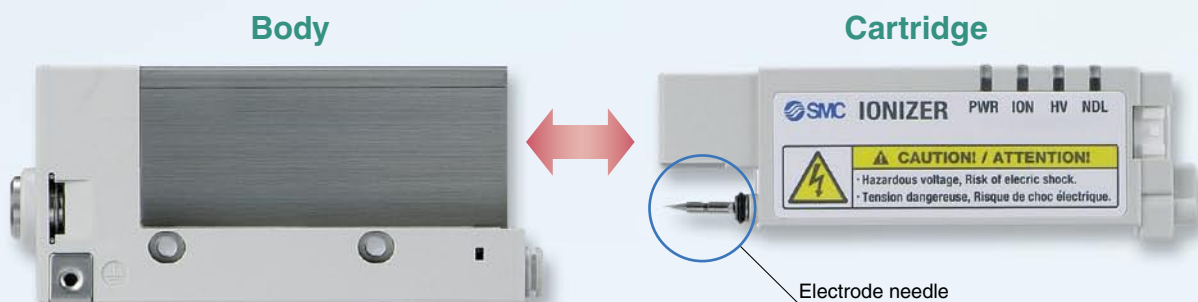

- Possible to conduct maintenance without removal of body.

- Tools unnecessary for the installation or removal of the cartridge!

Mounting variations

Direct mount

▶ Top through-hole mounting

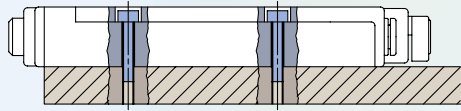

▶ Bottom tapped mounting

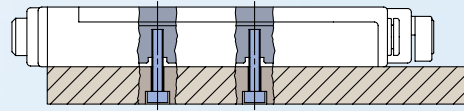

Bracket mount

▶ L-bracket

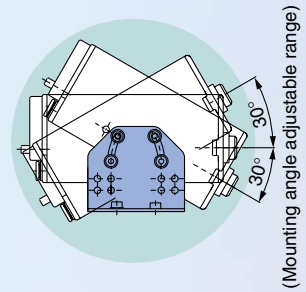
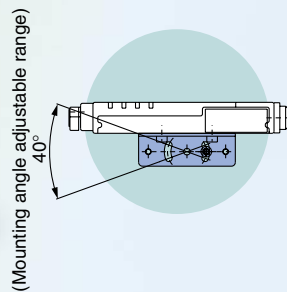

▶ Pivoting bracket

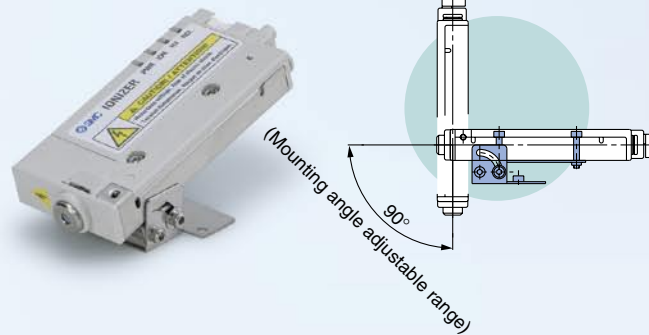

▶ DIN rail mounting bracket



• The L-bracket and the DIN rail mounting bracket can be used with the manifold.

Note) Static electricity elimination features are based on the data using the charged plate (size: 150 mm x 150 mm, capacitance: 20 pF) as defined in the U.S. ANSI standards (ANSI/ESD, STM3, 1-2000). Use this as a guideline purpose only for model selection because the value varies depending on the material and/or size of a subject.

Static Electricity Elimination Characteristics (Static Electricity Elimination Time from 1000 V to 100 V)

(1) Energy saving static electricity elimination nozzle / IZN10-01

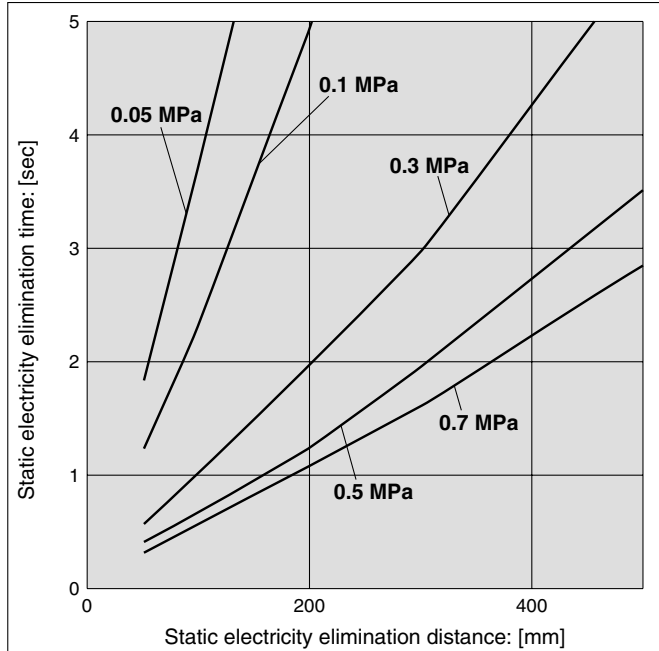

(2) High flow rate nozzle / IZN10-02

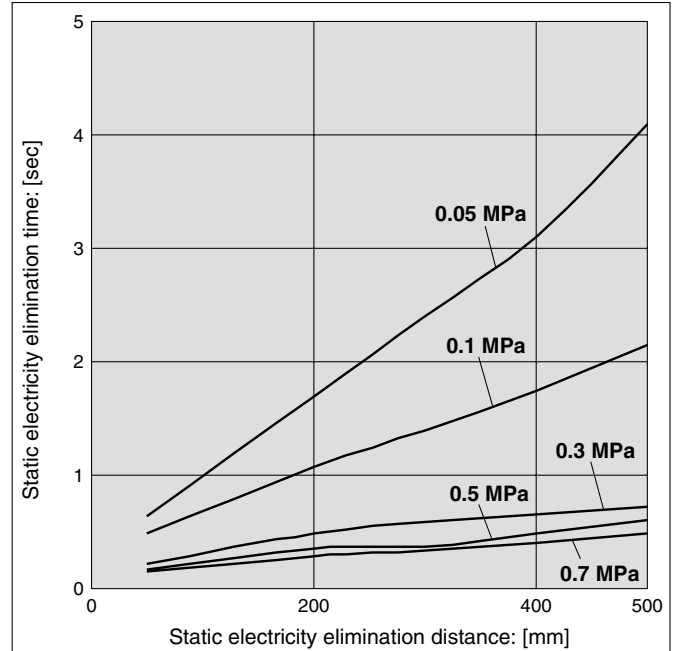

(3) Female threads for piping / IZN10-11 With Stainless steel 316 one-touch fitting / KQG + Anti-static tubing / TA□

* Static electricity elimination time at a distance of 50 mm from the end of tube.

KQG06-01S + TA□0604 (Tube I.D.: 4 mm)

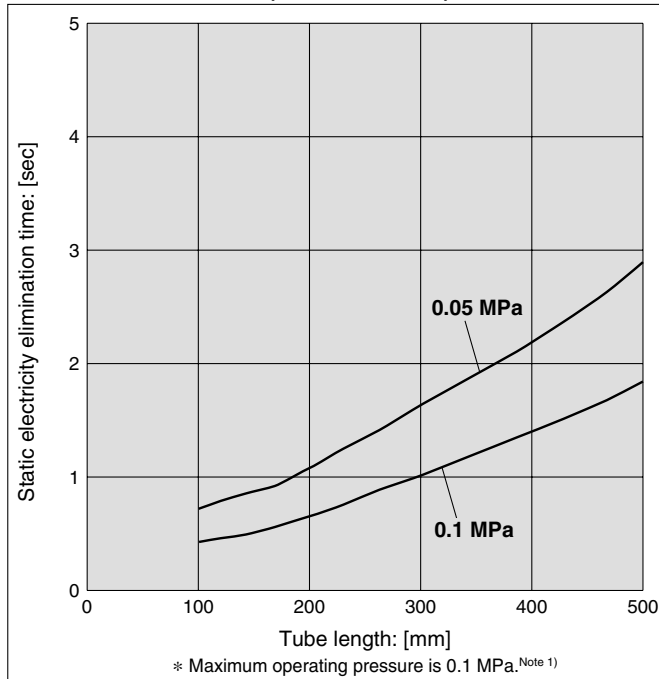

KQG08-01S + TA□0805 (Tube I.D.: 5 mm)

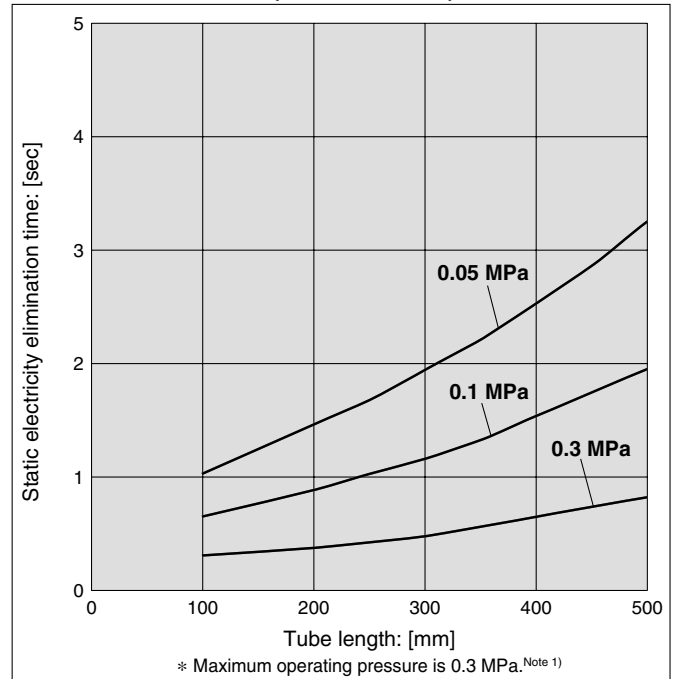

Note 1) If a pressure over the maximum operating pressure is applied, the electrode needle contamination detector will work and turn on the LED.

- The ion generating efficiency of the high frequency AC type ionizer will decrease when the pressure around the electrode needle reaches 0.1 MPa or more, due to its ion generating mechanism. This means that even when the electrode needle is not contaminated, the electrode needle contamination detector may work depending on the condition of the connected tube and other reasons.
- In the range where the contamination detection signal is generated, a small amount of ions are still generated, so it can be used in some operating conditions. In this case, please consider using a type without the contamination detector. (Page 5)
- When the tube is connected using the female threads for piping / IZN10-11, be sure to check static electricity elimination performance beforehand.

Note 2) The ionizer generates a small amount of ozone. Select ozone-resistant fittings for the female threads for piping. Also, regularly check there is no deterioration due to ozone.

Technical Data 1

Blow Velocity Distribution (Supply Pressure: 0.3 MPa)

(1) Energy saving static electricity elimination nozzle / IZN10-01

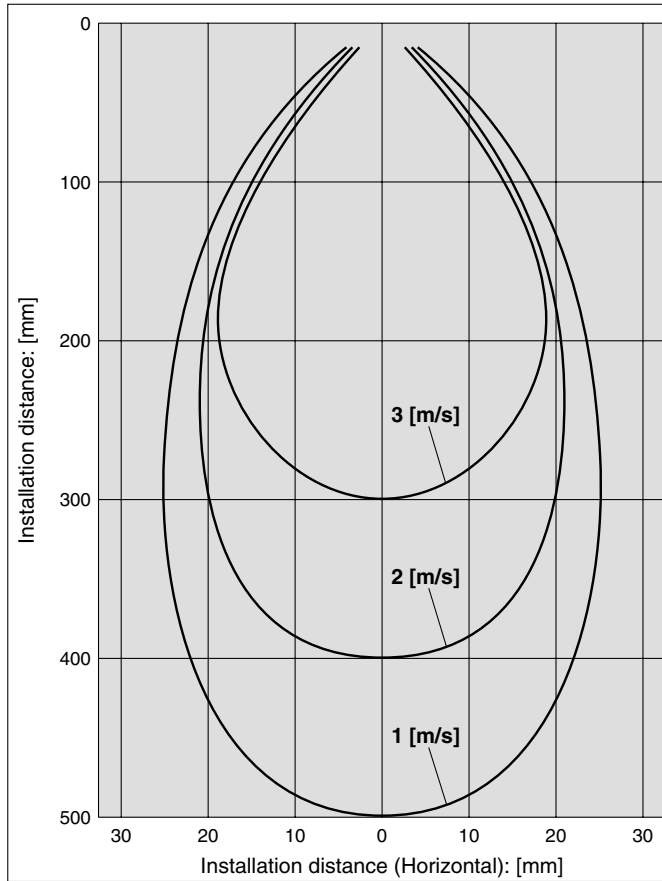
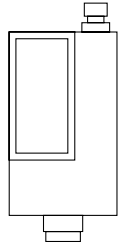

(2) High flow rate nozzle / IZN10-02

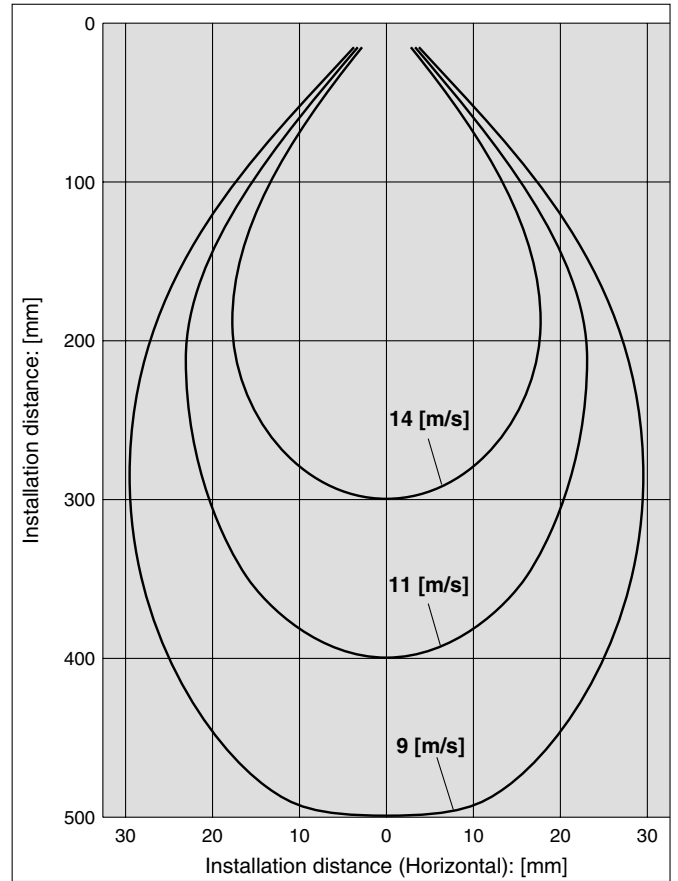
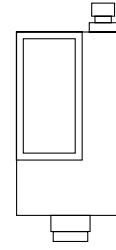

Flow Characteristics

- (1) Energy saving static electricity elimination nozzle / IZN10-01
- (2) High flow rate nozzle / IZN10-02

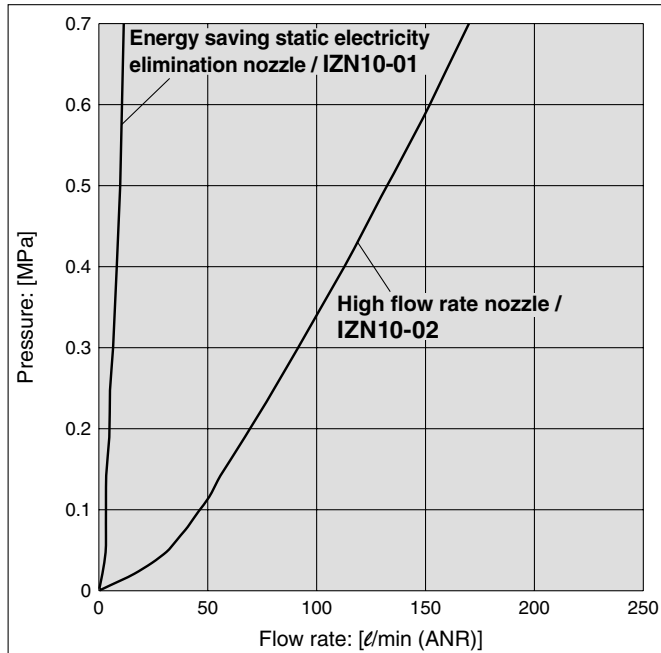

- (3) Female threads for piping / IZN10-11
With Stainless steel 316 one-touch fitting / KQG
+ Anti-static tubing / TA□

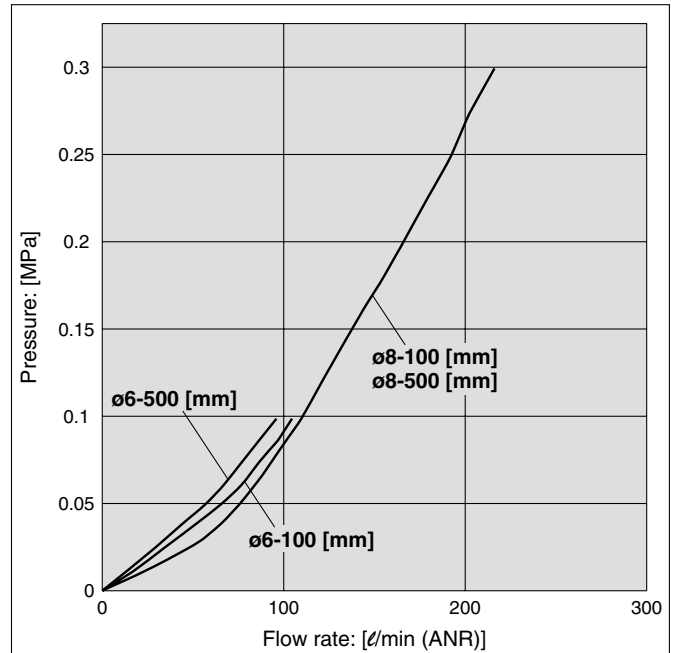

Note) When a pressure above each line is used, the electrode needle contamination detector will work and turn on the LED.
(Refer to the bottom note on page 1.)

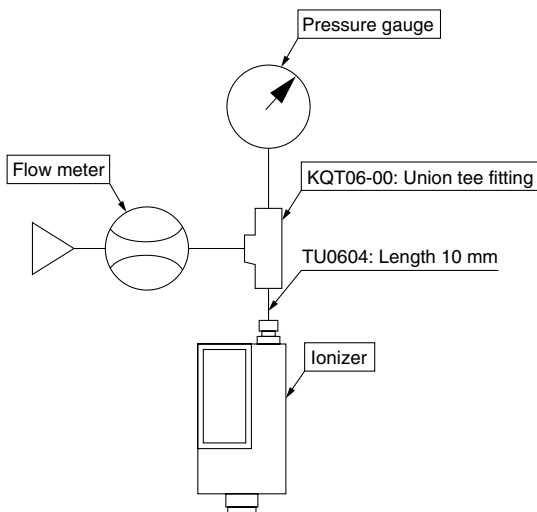
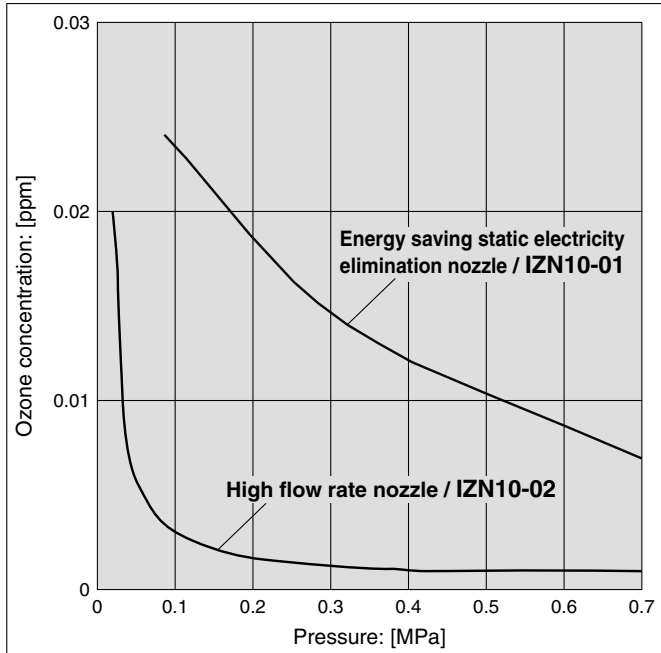

Fig. 1: Flow characteristics measuring circuit

Ozone Concentration

- (1) Energy saving static electricity elimination nozzle / IZN10-01
- (2) High flow rate nozzle / IZN10-02



Note) Ozone condensation can increase in an enclosed space.
Check the ozone condensation of the operating environment before using.

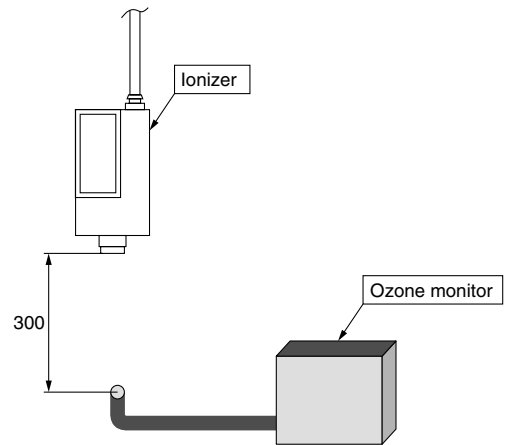

Fig. 2: Ozone condensation measuring circuit

Ionizer

Series IZN10

How to Order



IZN10-01 P 06 [] - []

High frequency AC nozzle type •

Nozzle type •

Symbol	Type
01	Energy saving static electricity elimination nozzle
02	High flow rate nozzle
11	Female threads for piping ^(Note)

Note) Used with a fitting and a tube on the end

Output specification •

Nil	NPN output
P	PNP output

Port size •

06	ø6: Metric size
07	ø6.35 (1/4): Inch size
16	ø6: Metric size (Elbow)
17	ø6.35 (1/4): Inch size (Elbow)

• Bracket

Nil	Without bracket
B1	With L-bracket
B2	With pivoting bracket
B3	With DIN rail mounting bracket

* Refer to page 6.

• Power supply cable

Nil	With power supply cable (3 m)
Z	With power supply cable (10 m)
N	Without power supply cable

Made to Order

Non-standard power supply cable length

How to Order	Contents/Specifications										
<p>IZN10-CP 01-X13</p> <p>Symbol Cable length</p> <table border="1"> <tbody> <tr> <td>01</td> <td>1 m</td> </tr> <tr> <td>02</td> <td>2 m</td> </tr> <tr> <td>⋮</td> <td>⋮</td> </tr> <tr> <td>19</td> <td>19 m</td> </tr> <tr> <td>20</td> <td>20 m</td> </tr> </tbody> </table>	01	1 m	02	2 m	⋮	⋮	19	19 m	20	20 m	<p>Model with made-to-order power supply cable Available in 1 m increments from 1 m to 20 m. Note) Use standard power supply cables for 3 m and 10 m lengths.</p>
01	1 m										
02	2 m										
⋮	⋮										
19	19 m										
20	20 m										

Without electrode needle contamination detector

How to Order	Contents/Specifications
<p>IZN10-11 [] [] [] - [] -X194</p> <p>• Fill in the standard model type shown above.</p> <p>Without electrode needle contamination detector •</p>	<p>With this specification, contamination detection signal is not generated when the pressure around the electrode needle increases due to tube piping etc. This specification is recommended when the tube needs to be extended.</p> <ul style="list-style-type: none"> The ion generating efficiency of the high frequency AC type ionizer will decrease when the pressure around the electrode needle reaches 0.1 MPa or more, due to its ion generating mechanism, and the contamination detection signal will be generated. However, in the range where the contamination detection signal is generated, a small amount of ions are still generated, so it can be used in some operating conditions.

Series IZN10

Accessories

Bracket

- L-bracket / IZN10-B1

- Pivoting bracket / IZN10-B2



Fixed mounting



Pivot mounting



- DIN rail mounting bracket / IZN10-B3

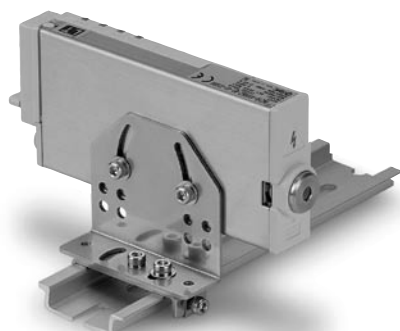

Single unit

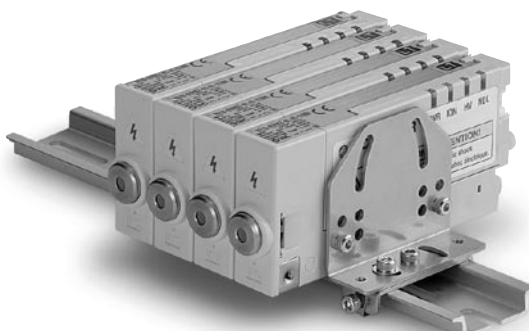

Manifold*

* The L-bracket and the DIN rail mounting bracket can be used with the manifold.

Power supply cable

- IZN10-CP (3 m)
- IZN10-CPZ (10 m)



Repair Parts

Electrode needle assembly / IZN10-NT



Electrode needle assembly

Options

Manifold mounting parts set

This set consists of a hexagon socket head cap screw, spacer and hexagon nut.

Note) The ionizer, L-bracket and DIN rail mounting bracket need to be prepared separately.

How to Order

IZN10-ES

Mounting pitch

Symbol	Pitch
ES	17 mm

Mounting stations

Symbol	Stations
2	2
3	3
4	4

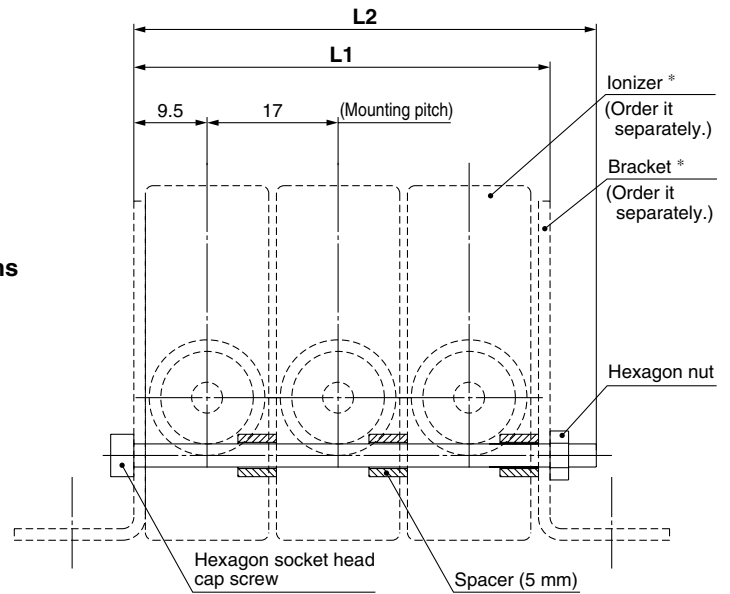
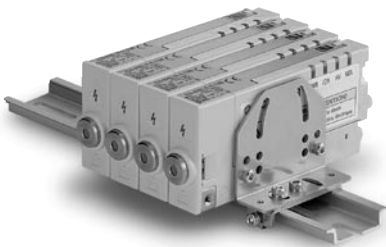

* Prepare two brackets and ionizer separately.

Part no.	L1	L2	Number of spacers
IZN10-ES2	37	40	2
IZN10-ES3	54	60	3
IZN10-ES4	71	75	4

AC adapter / IZN10-F-X196

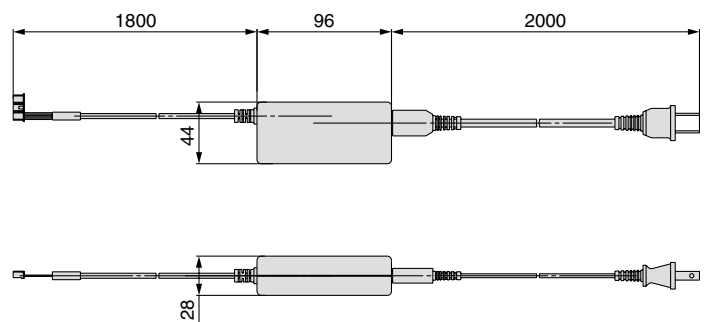

Note) Not applicable to PNP.

Electrode needle cleaning kit / IZS30-M2



Series IZN10

Specifications

Ionizer model		IZN10-□□ (NPN specification)	IZN10-□□P (PNP specification)
Ion generation method		Corona discharge type	
Method of applying voltage		High frequency AC type	
Discharge output <small>Note 1)</small>		2,500 V	
Ion balance <small>Note 2)</small>	Energy saving static electricity elimination nozzle	Within ±10 V	
	High flow rate nozzle	Within ±15 V	
Ozone generation <small>Note 3)</small>		0.03 ppm (0.05 ppm for energy saving static electricity elimination nozzle)	
Air purge	Fluid	Air (Clean dry air)	
	Operating pressure <small>Note 4)</small>	0.05 MPa to 0.7 MPa	
	Connecting tube size	ø6 / ø1/4 inch	
Power supply voltage		24 VDC ±10%	
Current consumption		80 mA	
Input signal	Discharge stop signal	Connected to GND (ON voltage: 0.6 V or less) Current consumption: 5 mA or less	Connected to +24 V (ON voltage: Between +19 V and power supply voltage) Current consumption: 5 mA or less
	Reset signal		
	External switch signal		
Output signal	Discharge signal	Max. load current: 40 mA Residual voltage: 1 V or less (load current at 40 mA) Max. applied voltage: 28 VDC	Max. load current: 40 mA Residual voltage: 1 V or less (load current at 40 mA)
	Error signal		
	Maintenance signal		
Effective static electricity elimination distance		20 mm to 500 mm	
Ambient and fluid temperature		0 to 55°C	
Ambient humidity		35 to 65%Rh	
Material		Housing: ABS, Stainless steel Nozzle: Stainless steel Electrode needle: Tungsten	
Vibration resistance		Durability: 50 Hz, Amplitude: 1 mm, XYZ each 2 hours	
Shock resistance		10 G	
Mass		120 g	
Standards/Directive		CE (EMC Directive: 2004/108/EC)	

Note 1) Measured with a probe of 1000 MΩ and 5 pF.

Note 2) Measured with a distance of 100 mm between the charged object and ionizer at an air purge pressure of 0.3 MPa.

For the static electricity elimination time, refer to technical data on page 1.

Note 3) Value above background level, measured with a distance of 300 mm from the front of the nozzle at an air purge pressure of 0.3 MPa.

Note 4) Static electricity cannot be eliminated without air purge.

Also, failure of air purge can increase internal ozone condensation, adversely affecting the ionizer and peripheral equipment. Be sure to perform air purge while energizing the ionizer.

Functions

1. Electrode needle contamination detection

Detects lowered static electricity elimination performance due to contamination or wear of the electrode needle. The maintenance LED lights up and maintenance signal is generated.

2. Signal inputs by external switch

There are 2 ports for external switch signal inputs.

Example

Emission of static electricity is suspended when abnormal purge air pressure is detected by pressure switch.

- Prevents static electricity elimination trouble due to pressure drop of compressed air.

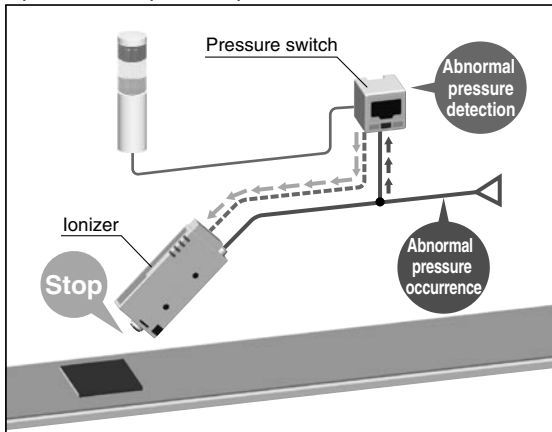

Example

An electrostatic meter is connected to stop discharge when static electricity elimination is completed.

- Energy can be saved by stopping discharge when static electricity elimination is completed.

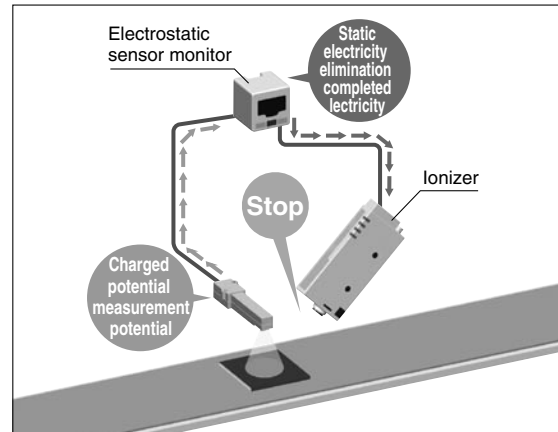

3. Description of LEDs

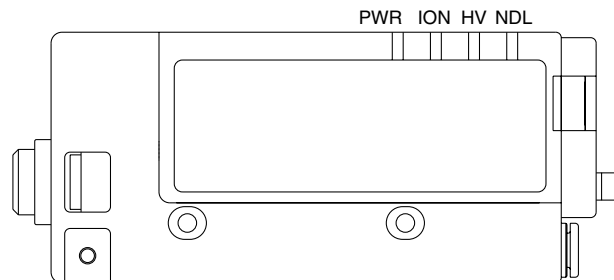

Description	Symbol	Color	Contents
Power supply display	PWR	Green	Lights up when the power supply is turned on.
Discharge	ION	Green	Lights up when static electricity is discharged.
Irregular high voltage display	HV	Red	Lights up when an irregular current flows on an electrode needle.
Maintenance display	NDL	Orange	Lights up when electrode needle contamination is detected.

(b) Behavior of LEDs

Items	PWR	ION	HV	NDL	Note
Normal operation (with discharge stop signal on)	○	○			Ions are being generated.
Normal operation (with discharge stop signal off)	○				Discharge stops.
Abnormal high voltage detected	○				Discharge stops when error is detected.
External switch signal 1	○		○		Discharge stops when the signal is turned on.
External switch signal 2	○				
Electrode needle contamination detected	○	○		○	Ions keep being generated even after the contamination is detected.

4. Alarm

Alarm item	Description	Corrective actions
High voltage error	Gives notification of the occurrence of an irregular current, such as high-voltage leakage. The ionizer stops discharging, turns on the HV LED. When error occurred, the signal output is turned off.	Turn off the power, solve the problem, then turn the power on again. If the error is solved during operation, turn the reset signal off and then on.
Maintenance electrode needle	Gives notification that electrode needle maintenance is necessary. The NDL LED turns on and a maintenance output signal is turned on.	Turn off the power, clean the electrode needles, and turn the power on again.

Series IZN10

Wiring

No.	Cable color	Description	I/O	Wiring requirement ^{Note)}	I/O	Specifications
1	Brown	Power supply +24 V	–	○	–	–
2	Blue	Power supply GND	–	○	–	–
3	Orange	Discharge stop signal	Input	○	Input	When the signal is turned off, discharge stops.
4	Pink	Reset signal	Input		Input	When the signal is turned on and then off, the error signal is reset. When the signal is turned off, normal operation continues.
5	White	Discharge signal	Output		Output	The signal stays on during discharge
6	Purple	Error signal	Output		Output	The signal is turned off when an error occurs
7	Yellow	Maintenance signal	Output		Output	The signal is turned on when maintenance is due.
8	Gray	External switch signal 1	Input		Input	When the signal is turned on, discharge stops.
9	Light blue	External switch signal 2	Input		Input	When the signal is turned on, discharge stops.

Note) Wiring requirement

○: Minimum wiring requirement for ionizer operation.

• Input signal

NPN: The signal is turned on when the power supply GND is connected, and turned off when disconnected.

PNP: The signal is turned on when the power supply 24 V is connected, and turned off when disconnected.

• Output signal

NPN: The signal is turned on when the output transistor is energized (by the power supply GND inside the ionizer), and turned off when de-energized.

PNP: The signal is turned on when the output transistor is energized (by the 24 V power supply inside the ionizer), and turned off when de-energized.

Provide Grounding.

- Provide class D ground to the tap for ground wiring or metal ( shaded) parts around the external face of the ionizer.

If grounding is not provided or is incomplete, the ionizer will not be able to achieve its specified static electricity elimination performance.

Also, the maintenance signal will be generated.

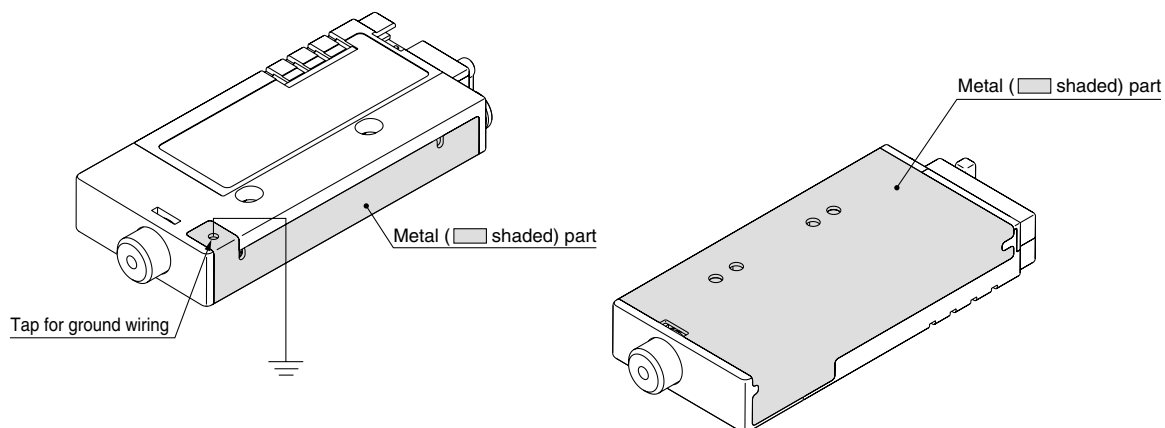

Power Supply Cable Connection Circuit

■ NPN

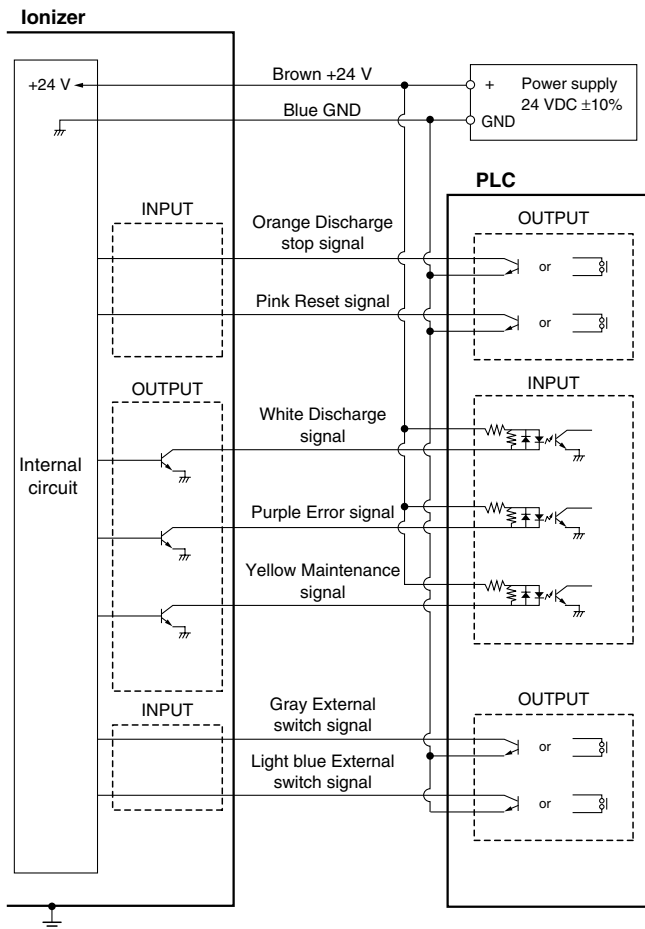

Class D grounding to external metal parts
(no electrical connection to internal circuit)

■ PNP

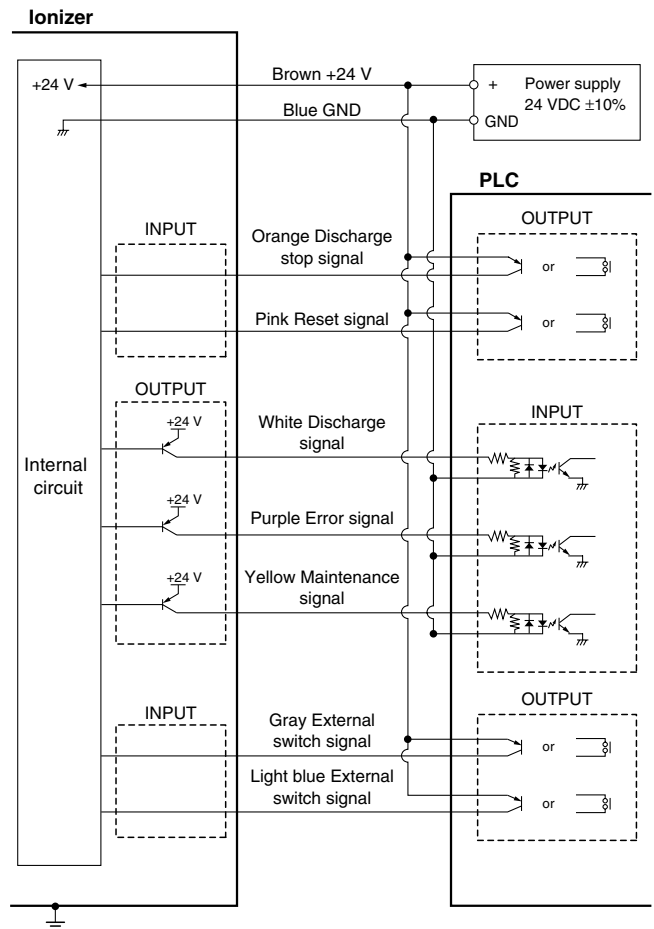

Class D grounding to external metal parts
(no electrical connection to internal circuit)

Timing Chart

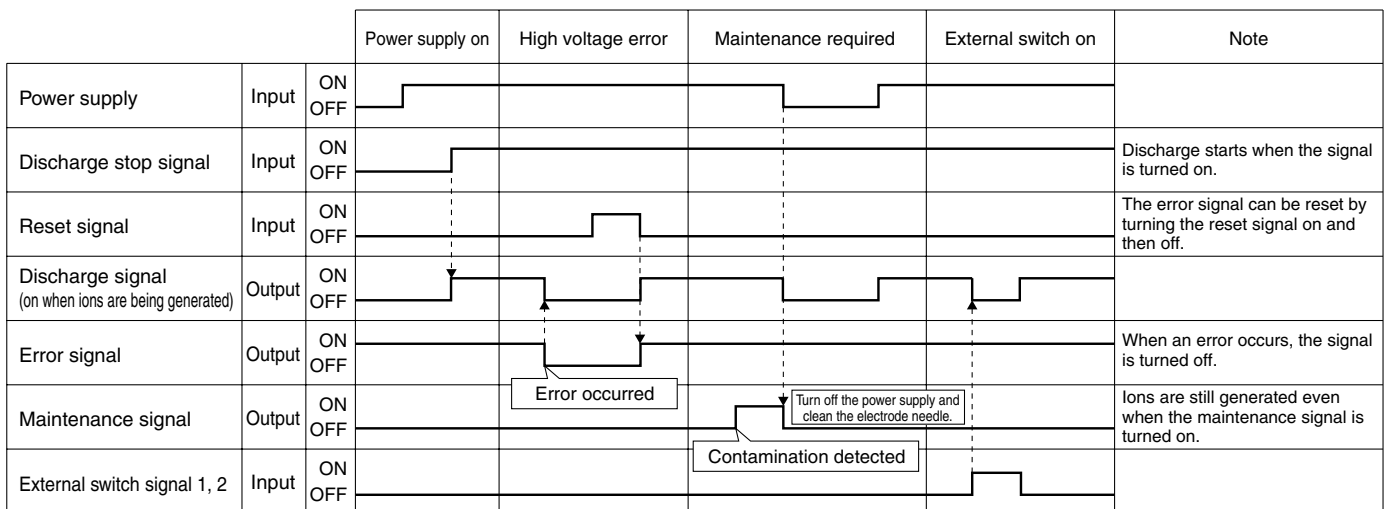

Series IZN10

Dimensions

Energy saving static electricity elimination nozzle / IZN10-01 □₀₆⁰⁶

High flow rate nozzle / IZN10-02 □₀₇⁰⁶

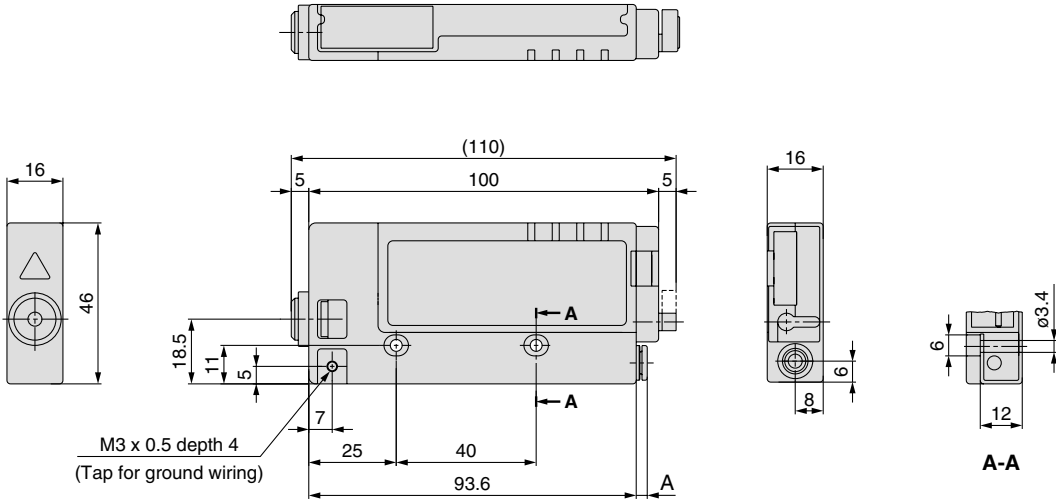

		(mm)
Model		A
IZN10- ⁰¹ □ ₀₂ □ ₀₆ (mm)		3.5
IZN10- ⁰¹ □ ₀₂ □ ₀₇ (inch)		7

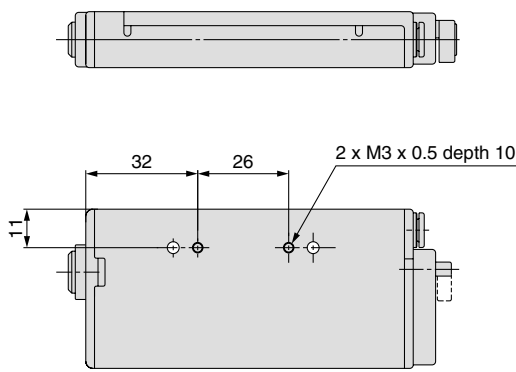

Elbow for piping port / IZN10-□□₁₇¹⁶

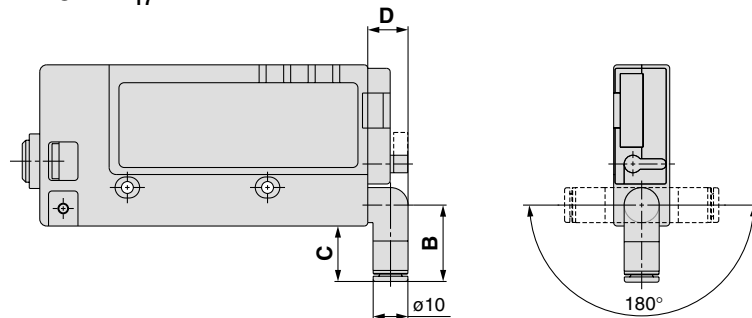

				(mm)
Model	B	C	D	
IZN10-□□ ₁₆ (mm)	22	16	11.5	
IZN10-□□ ₁₇ (inch)	24.5	18.5	12	

IZN10-11

Female threads for piping (Rc1/8)

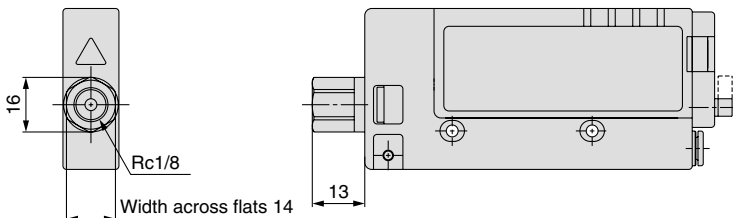

Dimensions

L-bracket / IZN10-B1

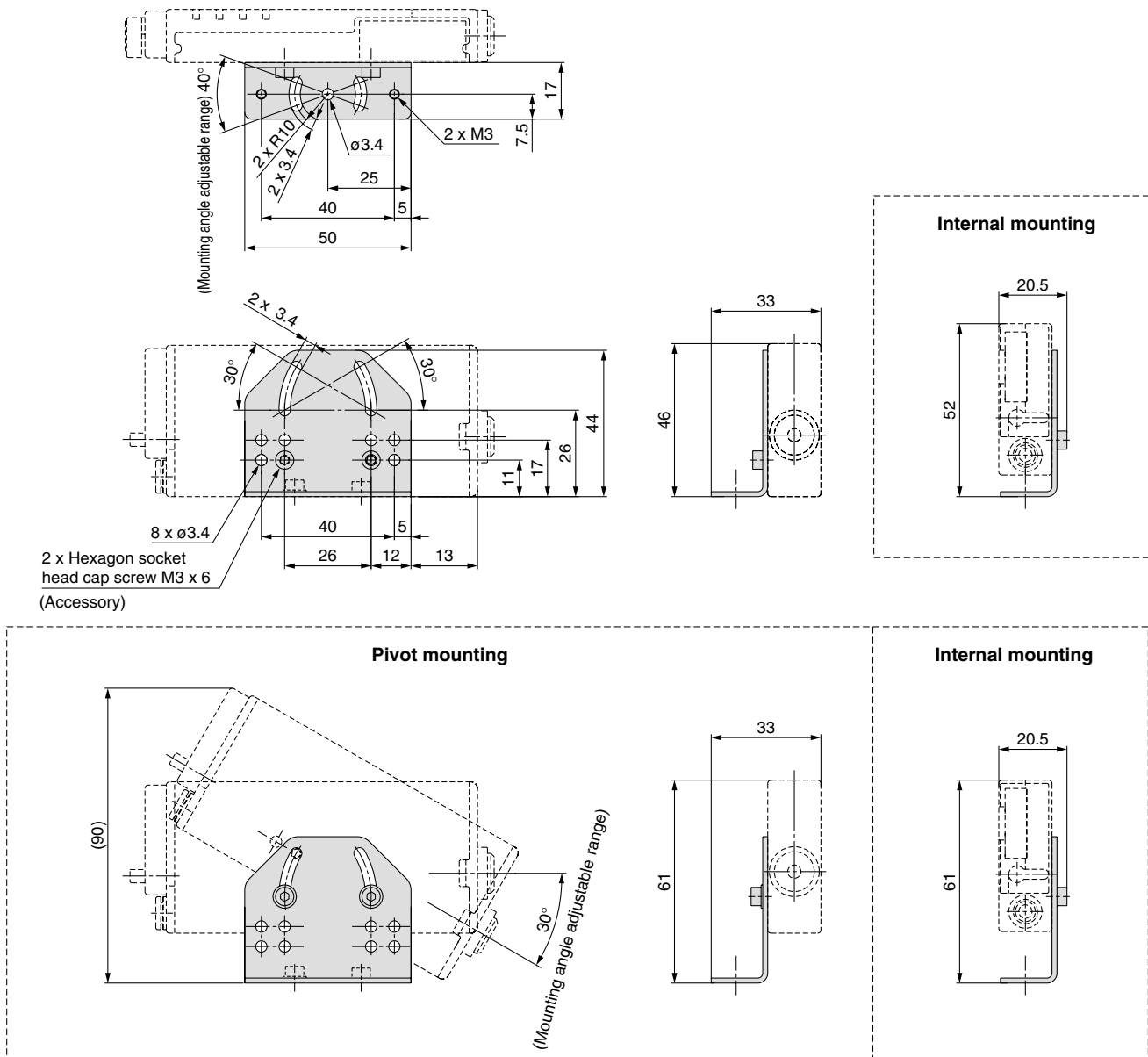

Pivoting bracket / IZN10-B2

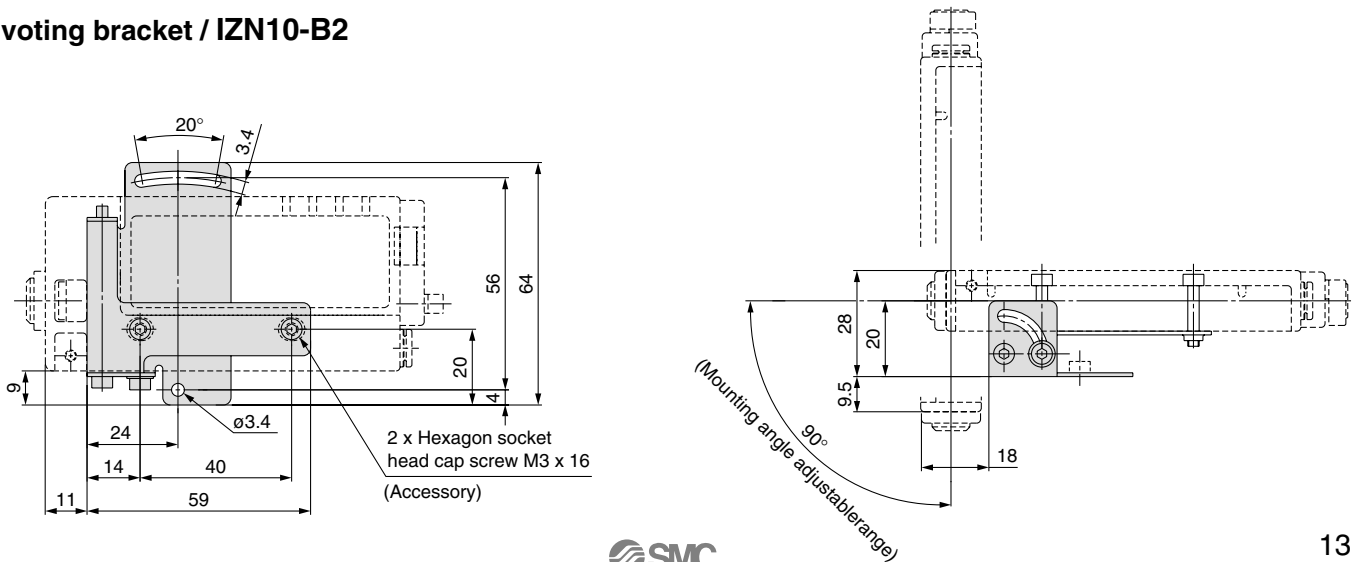

Series IZN10

Dimensions

DIN rail mounting bracket / IZN10-B3

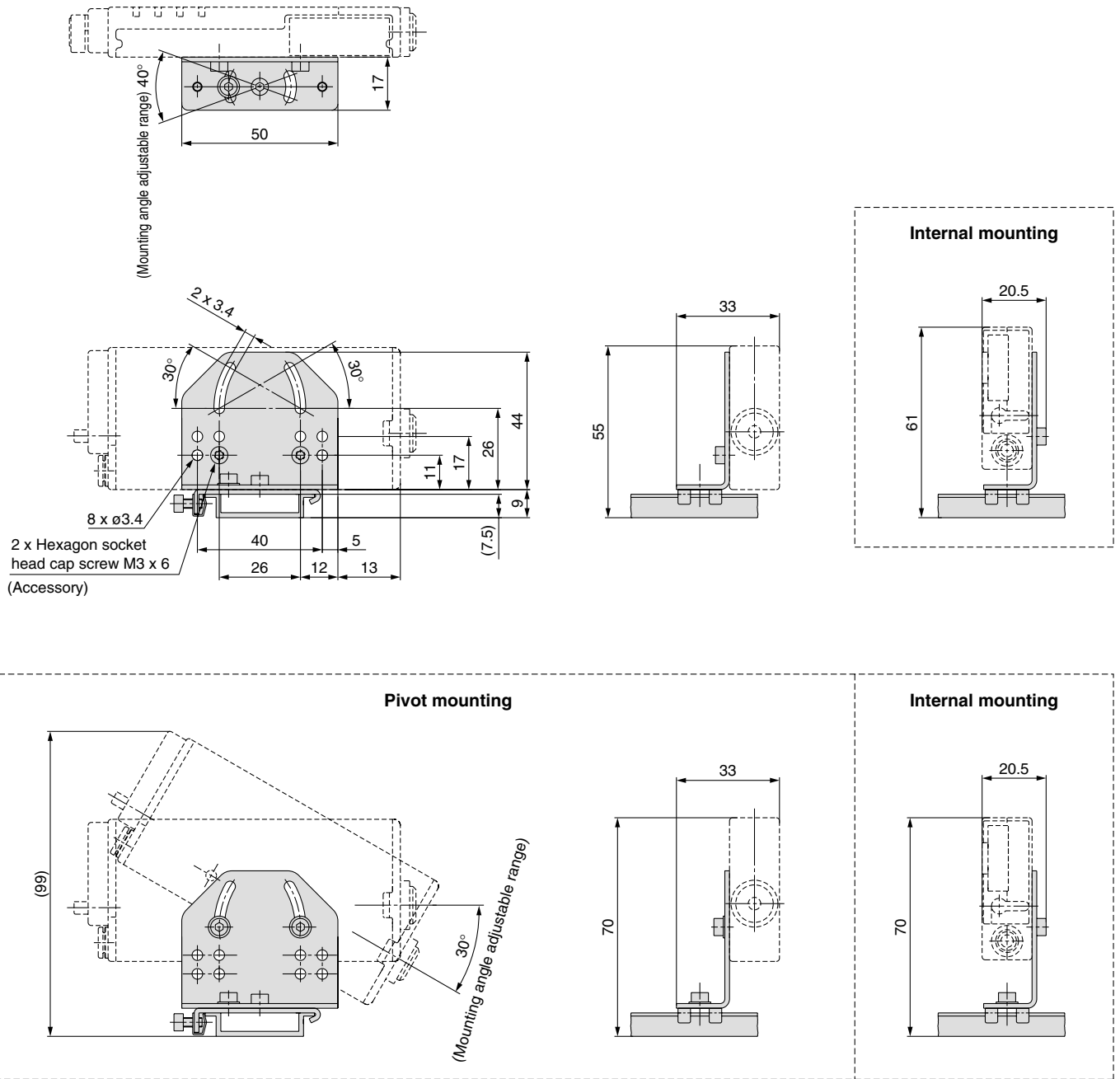





Safety Instructions

These safety instructions are intended to prevent hazardous situations and/or equipment damage. These instructions indicate the level of potential hazard with the labels of “**Caution**,” “**Warning**” or “**Danger**.” They are all important notes for safety and must be followed in addition to International Standards (ISO/IEC), Japan Industrial Standards (JIS)*1) and other safety regulations*2).

*1) ISO 4414: Pneumatic fluid power -- General rules relating to systems.
ISO 4413: Hydraulic fluid power -- General rules relating to systems.
IEC 60204-1: Safety of machinery -- Electrical equipment of machines. (Part 1: General requirements)
ISO 10218-1992: Manipulating industrial robots -Safety.
JIS B 8370: General rules for pneumatic equipment.
JIS B 8361: General rules for hydraulic equipment.
JIS B 9960-1: Safety of machinery - Electrical equipment of machines. (Part 1: General requirements)
JIS B 8433-1993: Manipulating industrial robots - Safety.
etc.

*2) Labor Safety and Sanitation Law, etc.

 **Caution:** Operator error could result in injury or equipment damage.

 **Warning:** Operator error could result in serious injury or loss of life.

 **Danger :** In extreme conditions, there is a possibility of serious injury or loss of life.

Warning

1. The compatibility of the product is the responsibility of the person who designs the equipment or decides its specifications.

Since the product specified here is used under various operating conditions, its compatibility with specific equipment must be decided by the person who designs the equipment or decides its specifications based on necessary analysis and test results. The expected performance and safety assurance of the equipment will be the responsibility of the person who has determined its compatibility with the product. This person should also continuously review all specifications of the product referring to its latest catalog information, with a view to giving due consideration to any possibility of equipment failure when configuring the equipment.

2. Only personnel with appropriate training should operate machinery and equipment.

The product specified here may become unsafe if handled incorrectly. The assembly, operation and maintenance of machines or equipment including our products must be performed by an operator who is appropriately trained and experienced.

3. Do not service or attempt to remove product and machinery/equipment until safety is confirmed.

1. The inspection and maintenance of machinery/equipment should only be performed after measures to prevent falling or runaway of the driven objects have been confirmed.
2. When the product is to be removed, confirm that the safety measures as mentioned above are implemented and the power from any appropriate source is cut, and read and understand the specific product precautions of all relevant products carefully.
3. Before machinery/equipment is restarted, take measures to prevent unexpected operation and malfunction.

4. Contact SMC beforehand and take special consideration of safety measures if the product is to be used in any of the following conditions.

1. Conditions and environments outside of the given specifications, or use outdoors or in a place exposed to direct sunlight.
2. Installation on equipment in conjunction with atomic energy, railways, air navigation, space, shipping, vehicles, military, medical treatment, combustion and recreation, or equipment in contact with food and beverages, emergency stop circuits, clutch and brake circuits in press applications, safety equipment or other applications unsuitable for the standard specifications described in the product catalog.
3. An application which could have negative effects on people, property, or animals requiring special safety analysis.
4. Use in an interlock circuit, which requires the provision of double interlock for possible failure by using a mechanical protective function, and periodical checks to confirm proper operation.



Safety Instructions

Caution

1. The product is provided for use in manufacturing industries.

The product herein described is basically provided for peaceful use in manufacturing industries.

If considering using the product in other industries, consult SMC beforehand and exchange specifications or a contract if necessary.

If anything is unclear, contact your nearest sales branch.

Limited warranty and Disclaimer/Compliance Requirements

The product used is subject to the following “Limited warranty and Disclaimer” and “Compliance Requirements”.

Read and accept them before using the product.

Limited warranty and Disclaimer

1. The warranty period of the product is 1 year in service or 1.5 years after the product is delivered.*3)

Also, the product may have specified durability, running distance or replacement parts. Please consult your nearest sales branch.

2. For any failure or damage reported within the warranty period which is clearly our responsibility, a replacement product or necessary parts will be provided.

This limited warranty applies only to our product independently, and not to any other damage incurred due to the failure of the product.

3. Prior to using SMC products, please read and understand the warranty terms and disclaimers noted in the specified catalog for the particular products.

***3) Vacuum pads are excluded from this 1 year warranty.**

A vacuum pad is a consumable part, so it is warranted for a year after it is delivered.

Also, even within the warranty period, the wear of a product due to the use of the vacuum pad or failure due to the deterioration of rubber material are not covered by the limited warranty.

Compliance Requirements

When the product is exported, strictly follow the laws required by the Ministry of Economy, Trade and Industry (Foreign Exchange and Foreign Trade Control Law).



Series IZN10 Specific Product Precautions 1

Be sure to read this before handling.

Selection

Warning

1. This product is intended to be used with general factory automation (FA) equipment.

If considering using the product for other applications (especially those stipulated in 4 on back page 1), please consult with SMC beforehand.

2. Use this product within the specified voltage and temperature range.

Using outside of the specified voltage can cause a malfunction, damage, electrical shock, or fire.

3. Use clean compressed air for fluid.

This product is not explosion proof. Never use a flammable gas or an explosive gas as a fluid and never use this product in the presence of such gases.

Please contact us when fluids other than compressed air are used.

4. This product is not explosion-protected.

Never use this product in locations where the explosion of dust is likely to occur or flammable or explosive gases are used.

Caution

1. This product is not washed. When bringing into a clean room, flush for several minutes and confirm the required cleanliness before using.

Mounting

Warning

1. Reserve an enough space for maintenance, piping and wiring

Please take into consideration that the one-touch fittings for supplying air, need enough space for the air tubing to be easily attached/detached.

To avoid excessive stress on the connector and one-touch fitting, please take into consideration the air tubings minimum bending radius and avoid bending at acute angles.

Wiring with excessive twisting, bending, etc. can cause a malfunction, wire breakage, fire or air leakage.

Minimum bending radius: Power supply cable.....35 mm

(Note: Shown above is wiring with the fixed minimum allowable bending radius and at a temperature of 20 °C. If used under this temperature, the connector can receive excessive stress even though the minimum bending radius is allowable.)

Regarding the minimum bending radius of the air tubing, refer to the instruction manual or catalog for tubing.

2. If the ionizer is to be mounted directly, mount it on a flat face.

If the mounting face is curved, distorted and/or uneven, excessive force will be applied to the ionizer, which may cause damage and failure of the ionizer. Also, dropping or exposing the ioniser to other strong impact may cause failure or accident.

Mounting

Warning

3. Do not use this product in an area where noise (electric magnetic field or surge voltage, etc.) are generated.

Using the ionizer under such conditions may cause it to malfunction or internal devices to deteriorate or break down. Take noise countermeasures and prevent the lines from mixing or coming into contact with each other.

4. Observe the tightening torque requirements when installing the ionizer. Refer to the following table for tightening torques for screws, etc.

If overtightened with a high torque, the mounting screws or mounting brackets may break. Also, if under tightened with a low torque, the connection may loosen.

Thread size	Recommended tightening torque
M3	0.61 to 0.63 N·m

5. Do not allow foreign matter or tools to enter the nozzle.

The inside of the nozzle contains electrode needles. If a metal tool makes contact with the electrode needles, it can cause electric shock, resulting in a sudden movement by the operator that can cause further injuries such as hitting the body on peripheral equipment. Also, if the tool damages the electrode needle, the ionizer may fail or cause an accident.

Danger High Voltage!

Electrode needles are under high voltage. Never touch them as there is a danger of electric shock or injury due to an evasive action against a momentary electrical shock caused by inserting foreign matter in the electrode cartridge or touching the electrode needle.

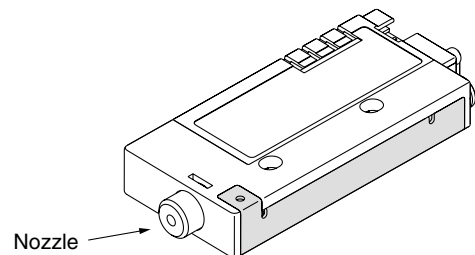

6. Do not apply moment to the nozzle.

If a copper long nozzle is mounted horizontally, moment will be applied to the nozzle. Then if vibration occurs, the nozzle can be damaged. If a moment of 0.05 N·m or more will be applied, mount a support to the middle part of the nozzle so that the moment is not applied to the nozzle.

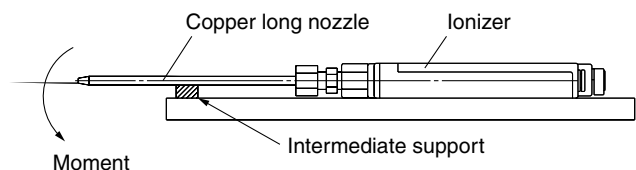

7. Do not affix any tape or seals to the main unit.

If the tape or seal contains any conductive adhesive or reflective paint, a dielectric phenomenon may occur due to ions arising from such substances, resulting in electrostatic charging or electric leakage.

8. Installation and adjustment should be conducted after turning off the power supply.



Series IZN10 Specific Product Precautions 2

Be sure to read this before handling.

Wiring / Piping

⚠ Warning

1. Before wiring confirm if the power supply voltage is enough and that it is within the specifications before wiring.
2. Always use a UL listed Class 2 output 24 VDC power supply.
3. Be sure to provide Class D grounding in order to maintain product performance.

If such grounding is not provided, not only may static electricity removal capability be disrupted but electric shocks may also result and the ionizer or power supply may break down.

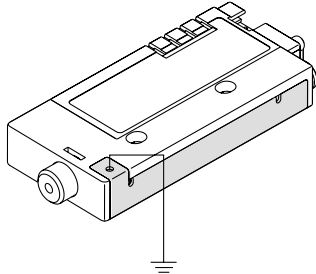

4. Be sure to turn off the power supply before wiring (including attachment/detachment of the connector).
5. When applying the power supply, pay special attention to the wiring and/or surrounding environment until the safety is confirmed.
6. Do not connect or remove any connectors including the power supply, while power is being supplied. Otherwise, the ionizer may malfunction.
7. If the power line and high pressure line are routed together, this product may malfunction due to noise. Therefore, use a separate wiring route for this product.
8. Be sure to confirm there are no wiring errors before starting this product.
Incorrect wiring will lead to damage or malfunction to the product.
9. Flush the piping before using.

Before using this product, exercise caution to prevent particles, water drop, or oil from entering the piping.

Operating Environment / Storage Environment

⚠ Warning

1. Do not use this product in an enclosed space.

This product utilizes a corona discharge phenomenon. Do not use the product in an enclosed space as ozone and nitrogen oxides exist in such places, even though in marginal quantities.

Also, ozone condensation can increase if used in an enclosed space, which can affect the human body, so ventilation is necessary. Even if ventilation is secured, the use of two more ionizers in a narrow space can increase ozone condensation. Therefore, check that ozone condensation is not more than a standard value of 0.1 ppm in the operating environment while the ionizer is in operation.

Operating Environment / Storage Environment

⚠ Warning

2. Take preventative measures against ozone.
Equipment used around the ionizer should have ozone-prevention measures.
Also, regularly check that there is no deterioration due to ozone.
3. The ionizer cannot be used without air purge.
Without air purge, not only will the ionizer be unable to eliminate charge, but also the internal ozone condensation will increase and adversely affect the ionizer and peripheral equipment. Therefore, be sure to perform air purge when energizing the ionizer.
4. Observe the fluid and ambient temperature range.
Fluid and ambient temperature ranges are 0 to 55°C for the ionizer. Do not use the ionizer in locations subject to sudden temperature changes even if the ambient temperature range is within the specified limits, as condensation may result.
5. Environments to avoid
Avoid using and storing this product in the following environments since they may cause damage to this product.
 - a) Avoid using in a place that exceeds an ambient temperature range of 0 to 55°C.
 - b) Avoid using in a place that exceeds an ambient humidity range of 35 to 65% Rh.
 - c) Avoid using in a place where condensation occurs due to a drastic temperature change.
 - d) Avoid using in a place in the presence of corrosive or explosive gas or where there is a volatile combustible.
 - e) Avoid using in an atmosphere where there are particles, conductive iron powders, oil mist, salt, solvent, blown dust, cutting oil (water, liquid), etc.
 - f) Avoid using in a place where ventilated air from an air conditioner is directly applied to the product.
 - g) Avoid using in a closed place without ventilation.
 - h) Avoid using in direct sunlight or radiated heat.
 - i) Avoid using in a place where there is a strong magnetic noise (strong electric field, strong magnetic field, or surge).
 - j) Avoid using in a place where static electricity is discharged to the main body.
 - k) Avoid using in a place where a strong high frequency occurs.
 - l) Avoid using in a place where this product is likely to be damaged by lightning.
 - m) Avoid using in a place where direct vibration or shock is applied to the main body.
 - n) Avoid using in a place where there is a force large enough to deform this product or weight is applied to the product.

6. Do not use an air containing mist or dust.

The air containing mist or dust will cause the performance to decrease and shorten the maintenance cycle.

Supply clean compressed air by using an air dryer (IDF series), air filter (AF/AFF series), and mist separator (AFM/AM series)

7. The ionizer is not designed to withstand lightning.



Series IZN10 Specific Product Precautions 3

Be sure to read this before handling.

Maintenance

Warning

1. Periodically (for example, every two weeks) inspect the ionizer and clean the electrode needles.

Conduct a regular maintenance to see if the product is run having a disorder.

Maintenance should be conducted by a fully knowledgeable and experienced person about the equipment. Using for long periods of time will lower the static electricity eliminating performance, if particles attach to the electrode pin. When the maintenance signal LED lights up, clean the electrode needle. Replace the electrode cartridge, if the pins are worn and the static electricity eliminating performance does not return even after being cleaned.

Danger High Voltage!

This product contains a high voltage generation circuit. When performing maintenance inspection, be sure to confirm that the power supply to the ionizer is turned off. Never disassemble or modify the ionizer, as this may not only impair the product's functionality but could cause an electric shock or electric leakage.

2. The tube and fitting must be treated as consumable parts.

The tube and fitting that are connected to the female piping ports of the ionizer can deteriorate due to ozone and need to be replaced regularly or use an ozone-resistant type.

3. When cleaning the electrode pin or replacing the electrode cartridge, be sure to turn off the power supply to the main body.

Touching an electrode needle when it is electrified may result in electric shock or other accidents.

4. Do not disassemble or modify this product.

Otherwise, an electrical shock, damage and/or a fire may occur. Also, the disassembled or modified products may not achieve the performances guaranteed in the specifications, and exercise caution because the product will not be warranted.

5. Do not operate this product with wet hands.

Otherwise, an electrical shock or accident may occur.

Handling

Warning

1. Do not drop, bump or apply excessive impact (10 G or more) while handling.

Even though it does not appear to be damaged, the internal parts may be damaged and cause a malfunction.

2. When mounting/dismounting the cable, use your finger to pinch the claw of the modular plug, then attach/detach it correctly. Otherwise, modular plug mounting section may be damaged and cause a disorder.

Related Products

Ionizer *Series IZS31*

- Static electricity elimination time **0.3 seconds**
The speed of static electricity elimination has been increased by optimization of a feedback sensor and shape of a nozzle.

Conditions / Static buildup decreased from 1000 V to 100 V

Discharged object: Charged plate monitor (150 mm x 150 mm, capacitance 20 pF)

Installation distance: 200 mm (Tungsten electrode with air purge)



Auto-balance sensor

Measures the ion balance.



Feedback sensor

Detects the polarity of a discharged object and measures the charged voltage.

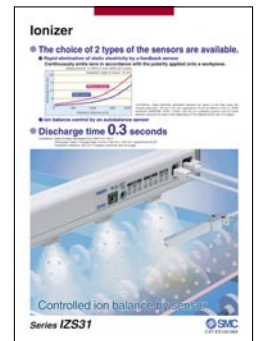

CAT.ES100-68

Electrostatic Sensor *Series IZD10* / Electrostatic Sensor Monitor *Series IZE11*

Electrostatic Sensor *Series IZD10*

The importance of the static electric control is put on confirming the “actual status”.

- Potential measurement: ± 20 kV (detected at a 50 mm distance)
 ± 0.4 kV (detected at a 25 mm distance)
- Detects the electrostatic potential and outputs in an analog voltage
 - Output voltage: 1 to 5 V (Output impedance: Approx. 100 Ω)
- Possible to measure electrostatic potential



CAT.ES100-65

Electrostatic Sensor Monitor *Series IZE11*

- Output: Switch output x 2 + Analog output (1 to 5 V, 4 to 20 mA)
- Minimum unit setting: 0.001 kV (at ± 0.4 kV), 0.1 kV (at ± 20 kV)
- Display accuracy: $\pm 0.5\%$ F.S. ± 1 digit or less
- Detection distance correction function (adjustable in 1 mm increments)
- Range switching supports two sensors. (± 0.4 kV, ± 20 kV)



Handheld Electrostatic Meter *Series IZH10*

The importance of the static electric control is put on confirming the “actual status”.

Easy-to-use handheld electrostatic meter

- Measuring range: ± 20.0 kV
- Minimum display unit: 0.1 kV (± 1.0 to ± 20.0 kV)
0.01 kV (0 to ± 0.99 kV)
- Compact & Lightweight: 85 g (excluding dry cell batteries)
- Backlight for reading in the dark
- LOW battery indicator
- Peak/Bottom display function
- Zero-out function
- Auto power-off function

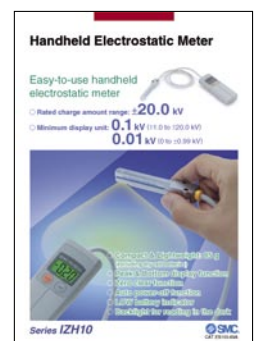

CAT.ES100-69



SMC can provide all the equipment required to supply air to the ionizer.

Consider the equipment below not only for providing an “opportunity to decrease maintenance” and “preventing damage” but also for an “energy-saving countermeasure”.

Recommended pneumatic circuit diagram

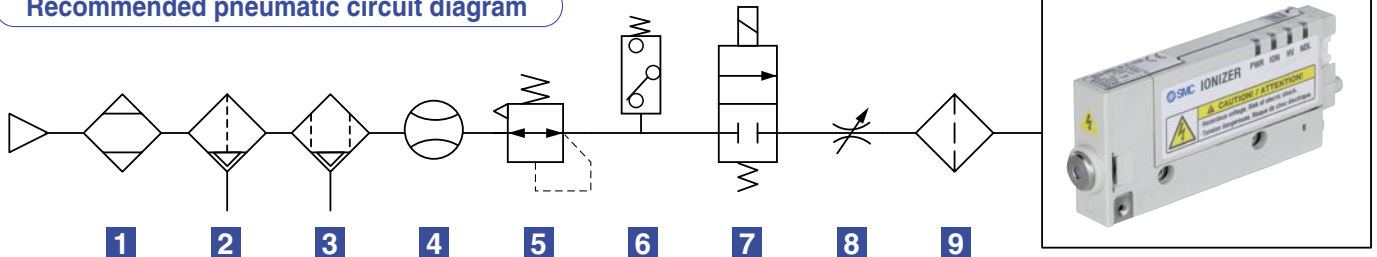

1 Air Dryer / Series IDF

Decreases the dew point of compressed air. Limits moisture generation which can lead to damage.



2 Air Filter / Series AF

Eliminates solid foreign matters such as powder particles in the compressed air.



3 Mist Separator / Series AFM

Eliminates oil mist which is difficult to eliminate with an air filter.



4 Digital Flow Switch / Series PF2A

Decreases the air consumption by flow control.



2-Color Display Digital Flow Switch / Series PFM



5 Regulator / Series AR

Decreases the air consumption by setting to an appropriate pressure.



6 Digital Pressure Switch / Series ISE30

The pressure control prevents the ability of static electricity removal from being reduced in accordance with the reduction of air pressure.



7 2 Port Solenoid Valve / Series VX



8 Restrictor / Series AS-X214

Regulates to the appropriate air volume depending upon the installation condition. Decreases the air consumption.



9 Clean Air Filter / Series SFD

Built-in capillary element
Nominal filtration rating: 0.01 μm
Adopted hollow fiber elements with over 99.99% filtering efficiency do not contaminate workpieces.



SMC Static Electricity Prevention Equipment



P-E06-15

For the details of this equipment, refer to “Static Electricity Prevention Equipment” pamphlet.

Publishing contents

- Examples of static electricity-related problems
- Antistatic equipment
- Static electricity elimination equipment
- Measurement equipment
- Technical data

SMC Corporation

Akihabara UDX 15F,
4-14-1, Sotokanda, Chiyoda-ku, Tokyo 101-0021, JAPAN
Phone: 03-5207-8249 Fax: 03-5298-5362
URL <http://www.smcworld.com>
© 2008 SMC Corporation All Rights Reserved

Specifications are subject to change without prior notice and any obligation on the part of the manufacturer.

D-KS

1st printing MP printing MP 13500KS Printed in Japan.

This catalog is printed on recycled paper with concern for the global environment.